



11.2 Degree Days

READ

Freezing winter weather or sweltering summer heat—in either condition, people use energy to keep their homes, schools, and businesses comfortable. You can use degree day values to help predict how much energy will be needed each month to heat or cool a building. In this activity, you will learn how degree day values are calculated and how to use them to evaluate energy needs.

Understanding degree days

Degree day values are calculated by comparing a day's average temperature to 65 °Fahrenheit. The more extreme the temperature, the higher the degree day value. For example, if the average daily temperature were 72°F, the degree day value would be **72 minus 65**, or 7. On a day with an average temperature of 35°F, the degree day value would be **65 minus 35**, or 30.

When the average daily temperature is *lower* than 65°F, we use the term **heating degree day value**, because you need to add heat to a building to bring it to a comfortable temperature. When the average daily temperature is *higher* than 65°F, we talk about the **cooling degree day value**.

We compare the daily average temperature to 65°F because 65°F is a temperature at which most people are comfortable without heating or air conditioning. If the average temperature is close to 65°F, you won't need to spend much money heating or cooling your home that day. However, if the average temperature is well above or below 65°F, you'll be spending a lot more money on electricity or fuel.

Heating Degree Day Values

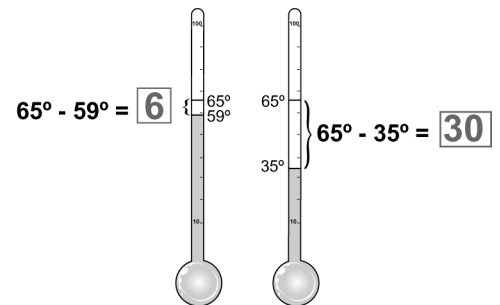

Cooling Degree Day Values

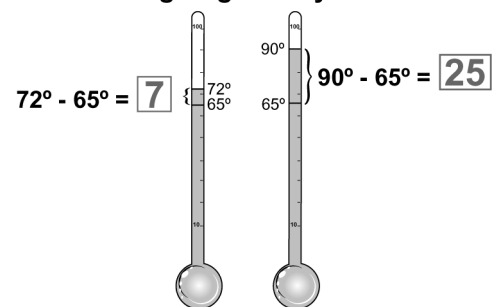
PRACTICE

- On July 22, 2002, the average daily temperature in St. Louis, Missouri, was 88°F. Calculate the cooling degree day value.

- On January 22, 2003, the average daily temperature in St. Louis was 14°F. Calculate the cooling degree day value.

- On which day—July 22, 2002 or January 22, 2003—was the heating degree day value zero? On which day was the cooling degree day value zero?



Using temperature data to calculate degree day values

The table below shows temperature data recorded by the National Weather Service in May 2003.

Table 1: Temperature data for St. Louis, May 1-14, 2003

Day	High temp (°F)	Low temp (°F)	Average temp (high +low)÷2	Heating degree day value	Cooling degree day value
1	73	61	$(73 + 61) \div 2 = 67$	0	2
2	63	52			
3	70	44			
4	65	52			
5	83	58			
6	79	59			
7	74	60			
8	71	53			
9	90	70			
10	82	62			
11	65	52			
12	71	52			
13	74	56			
14	75	60			
Two week totals:					

- Calculate the average temperature, the heating degree day value, and the cooling degree day value for each day. Record your answers in the Table 1. The first one is done for you.
- During the first two weeks of May, on how many days were St. Louis residents more likely to use their heating systems? On how many days were they more likely to cool their homes?

Calculating monthly totals for degree day values

- Find the sum of the numbers in the fifth column of Table 1. This will give you the *total heating degree day value* for May 1–14, 2003. Record your answer in the table's last row.
 - Find the *total cooling degree day value* for same time period by finding the sum of the sixth column of Table 1. Record your answer in the table's last row.
 - The total heating degree day value for May 15-31, 2003 was 31. The total cooling degree day value was 32. Find the *monthly* total heating and cooling degree day values.
-
- In St. Louis, the average total heating degree day value for May is 79. The average total cooling degree day value for May is 114. How was May 2003 different from the average? Do you think residents used more energy than usual to keep their homes comfortable, or less?



Using average monthly degree day values

The National Weather Service provides average monthly degree day values to help citizens better evaluate their energy needs.

Average monthly heating degree day (HDD) and cooling degree day (CDD) values for St. Louis

January		February		March		April		May		June	
HDD	CDD	HDD	CDD	HDD	CDD	HDD	CDD	HDD	CDD	HDD	CDD
1097	0	844	0	613	7	294	32	79	114	6	316

Average monthly heating degree day (HDD) and cooling degree day (CDD) values for St. Louis

July		August		September		October		November		December	
HDD	CDD	HDD	CDD	HDD	CDD	HDD	CDD	HDD	CDD	HDD	CDD
0	461	1	396	46	196	246	36	583	3	949	0

- On a separate piece of paper, make a bar graph showing the average monthly heating and cooling degree day values for St. Louis. Place months on the x -axis and monthly average degree day values on the y -axis. Use red bars for the heating degree day values and blue bars for the cooling degree day values. Use your graph to answer the following questions:
 - In which month should a St. Louis resident budget the most money for heating costs?

 - In which month should a St. Louis resident budget the most money for cooling costs?

 - In which month do you think a St. Louis resident will spend the least amount of money to keep their home at a comfortable temperature? Explain.

 - Challenge! What additional information would you need to calculate the actual monthly heating and cooling costs for a particular building?

