

# Period and Frequency

$$\begin{array}{l} \textit{Period} \\ \text{(seconds)} \end{array} \rightarrow T = \frac{1}{f}$$
$$\begin{array}{l} \textit{Frequency (hertz)} \end{array} \rightarrow f$$

$$\begin{array}{l} \textit{Frequency (hertz)} \\ f \end{array} = \frac{1}{T}$$
$$\begin{array}{l} \textit{Period} \\ \text{(seconds)} \end{array} \leftarrow T$$

**A period is the time to complete one cycle of harmonic motion.**

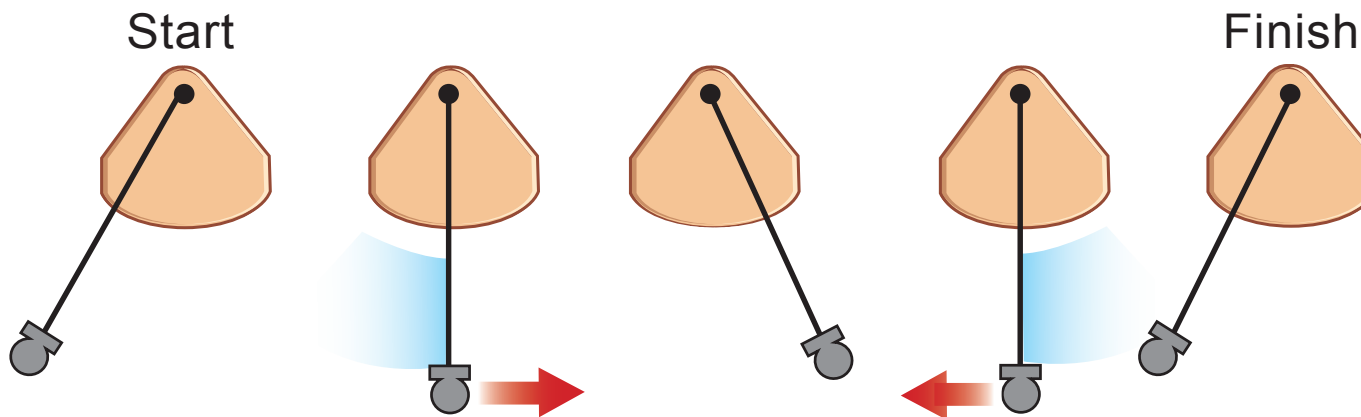

# Amplitude

$$\textit{Amplitude} = \frac{1}{2} (\text{high point} - \text{low point})$$

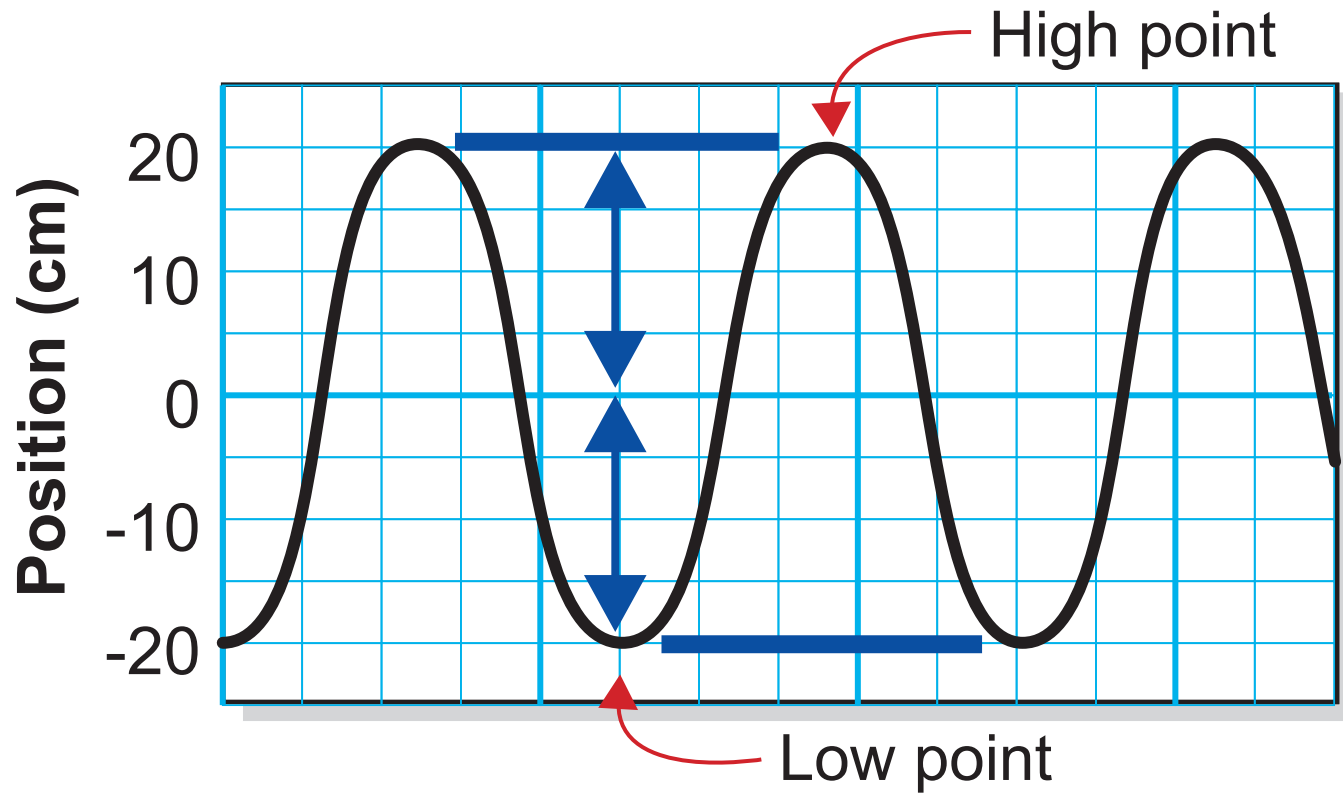

# Harmonic Motion Graphs

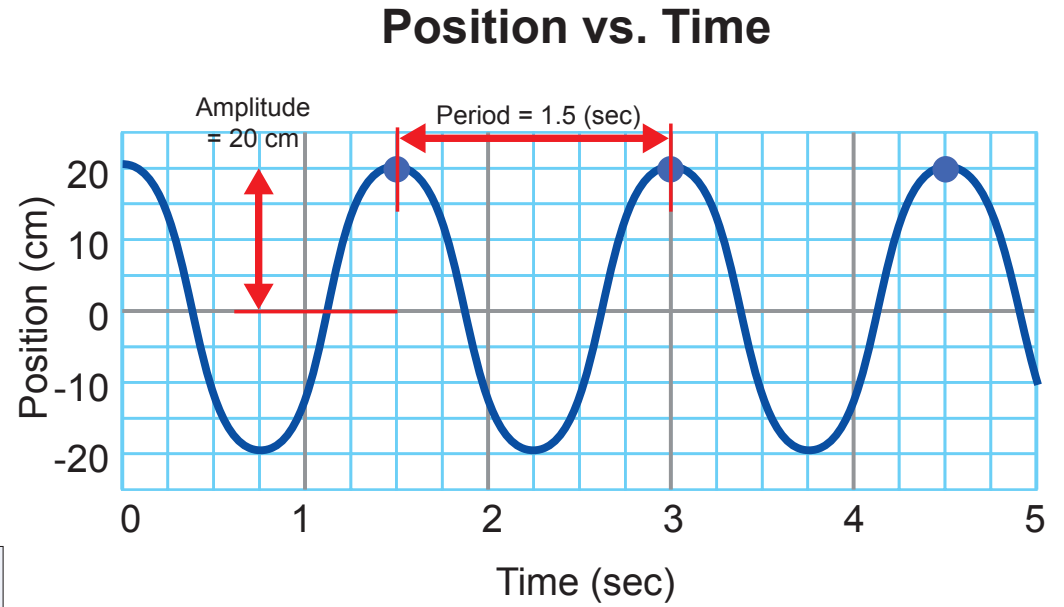
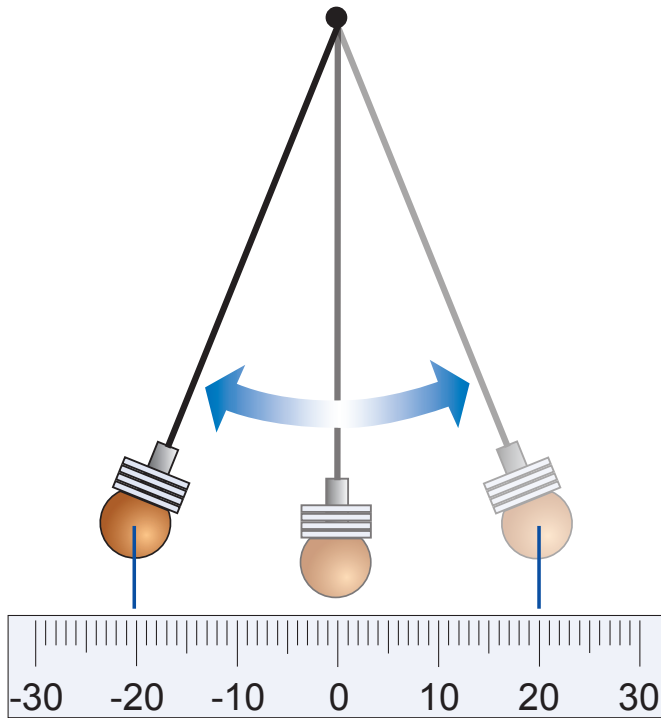

# Phase of Harmonic Motion

In phase

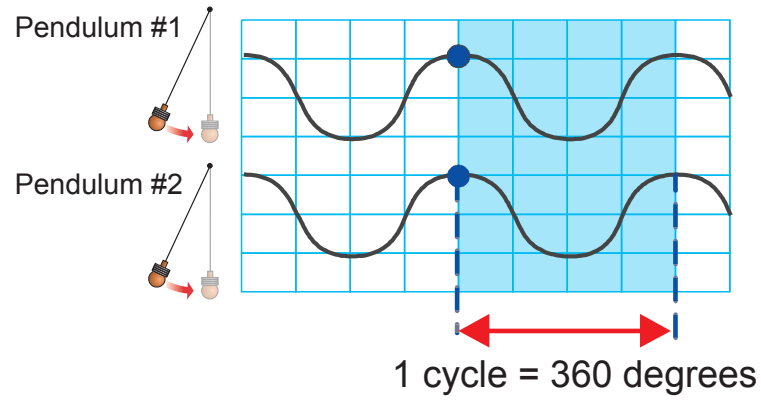

Out of phase

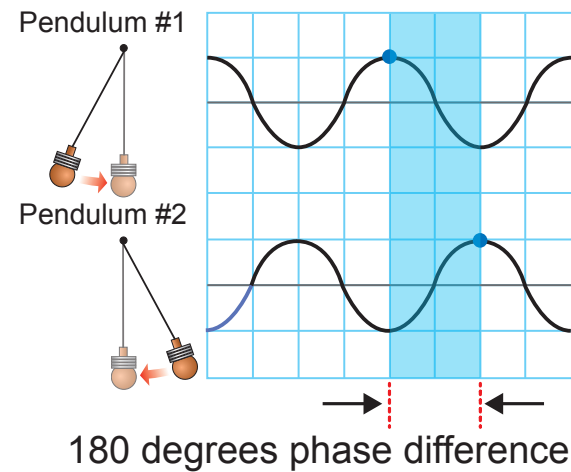
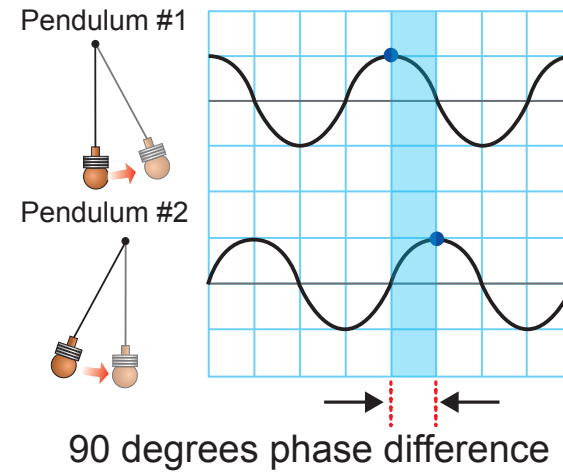

# Longitudinal Waves

**A LARGE SPRING**

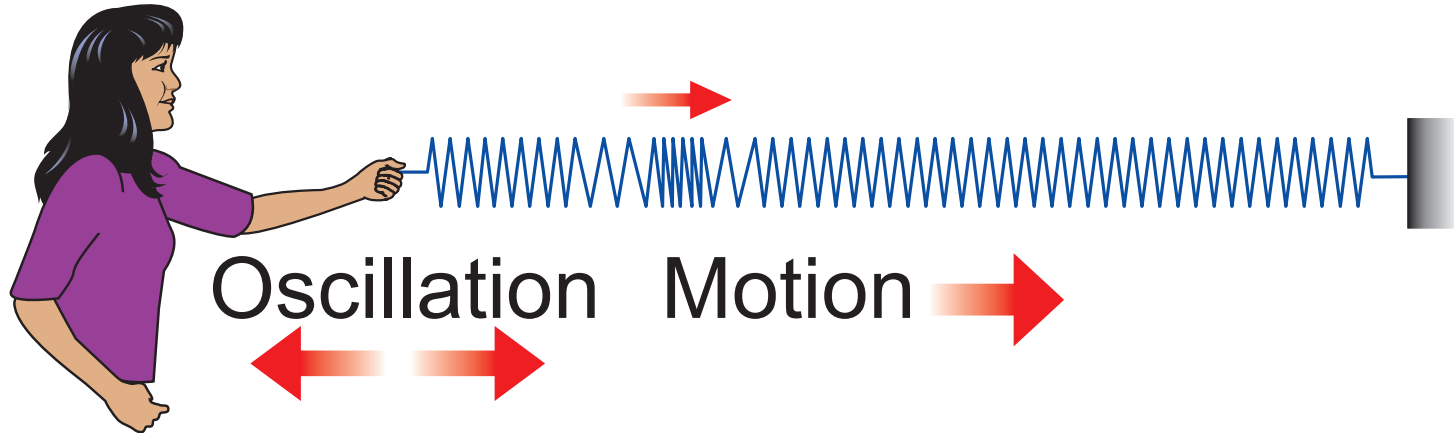

**SOUND WAVE**

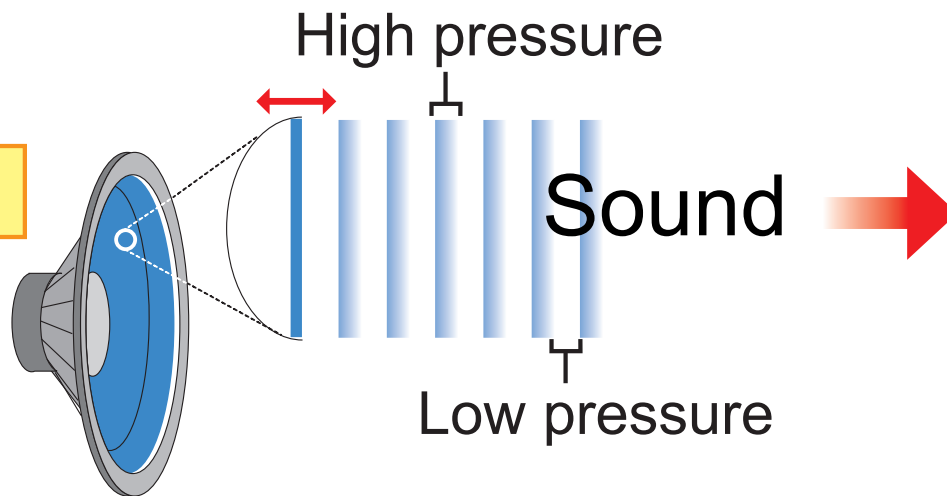

# Transverse Waves

Oscillation

**VIBRATING  
STRING**



Motion

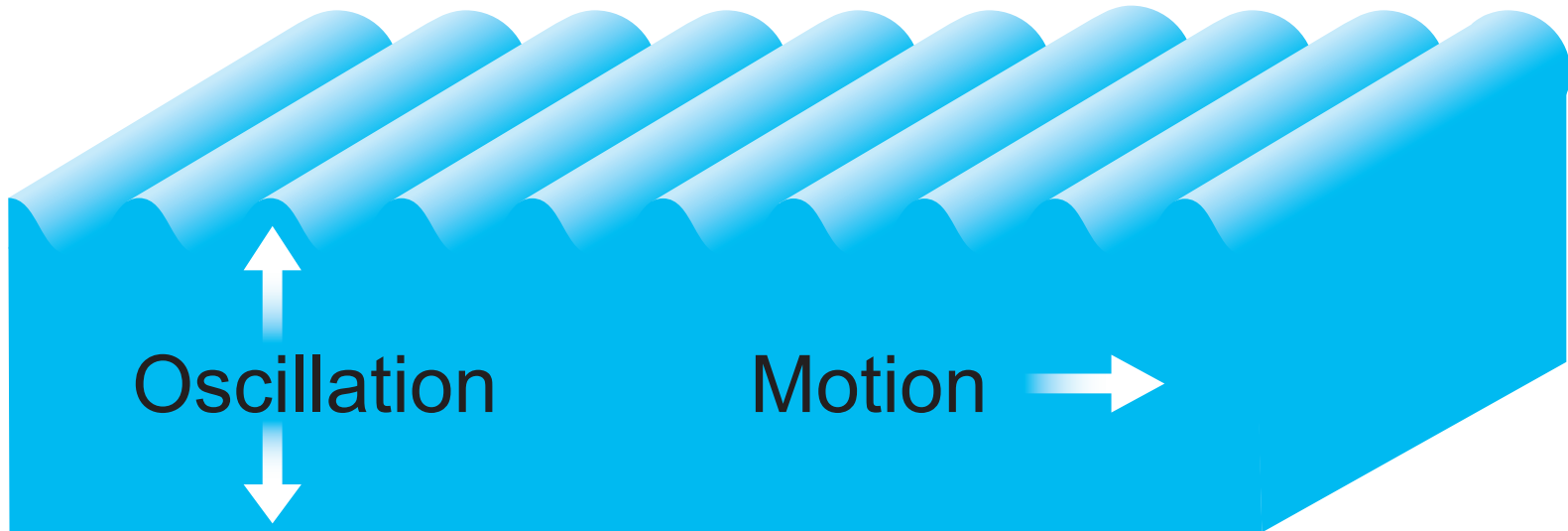

Oscillation

Motion



**WATER WAVE**

# The Speed of a Wave

$$\text{Speed (m/sec)} \longrightarrow v = f \lambda$$

*Frequency (hertz)* (pointing to  $f$ )  
*Wavelength (meters)* (pointing to  $\lambda$ )

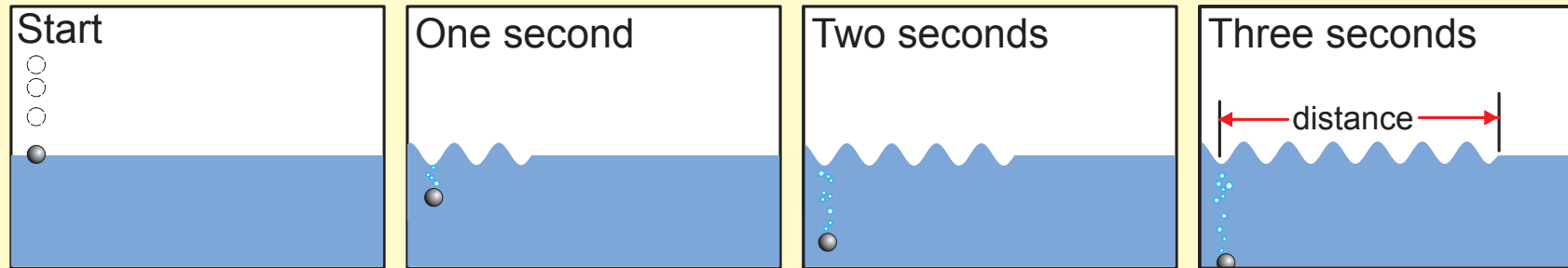

# Wave Interactions

## ABSORPTION

Wave is absorbed  
by a material and  
may disappear.

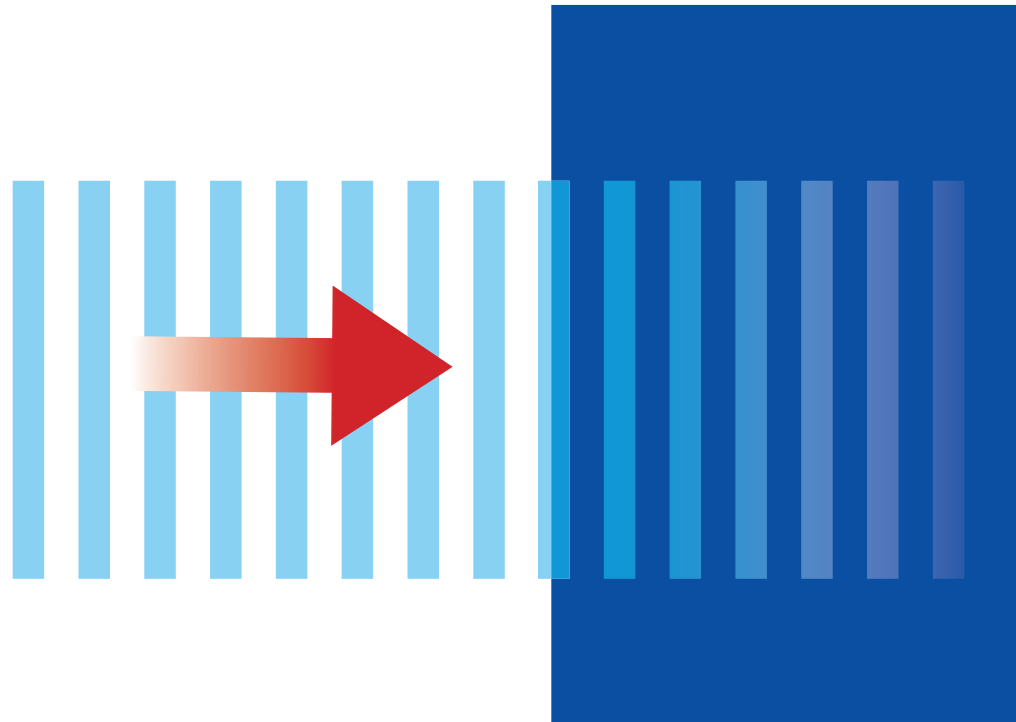

# Wave Interactions

## DIFFRACTION

Wave bends around  
or goes through a  
hole in a material.

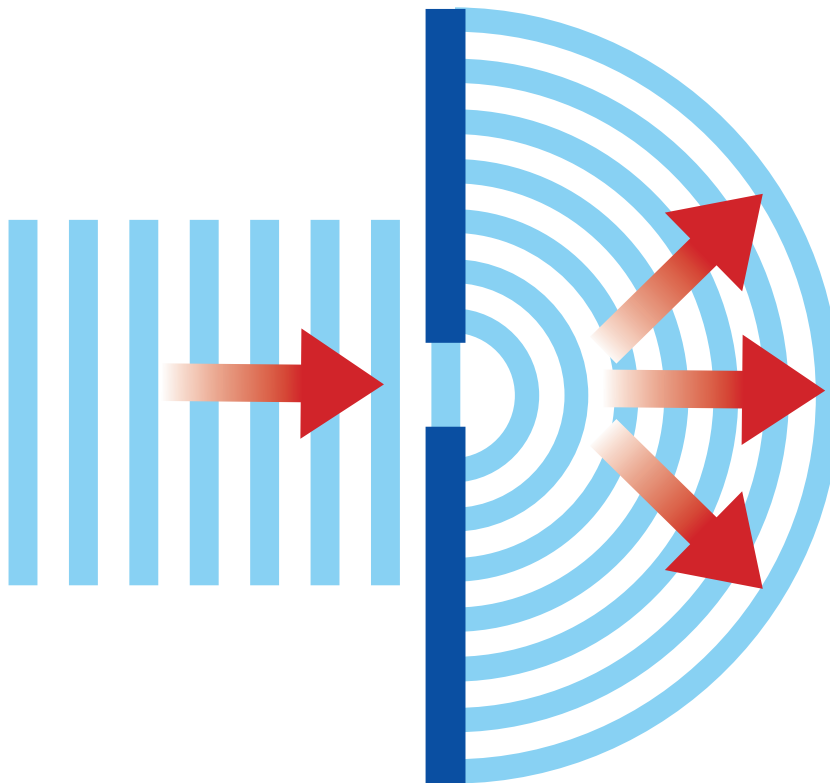

When plane waves go  
through a small hole, they  
become circular waves.

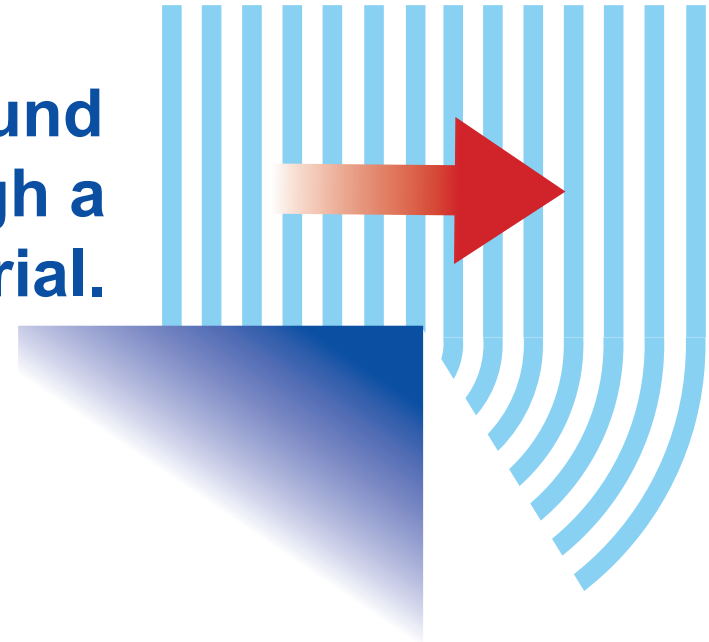

# Wave Interactions

## REFLECTION

Wave bounces off a material and goes in a new direction.

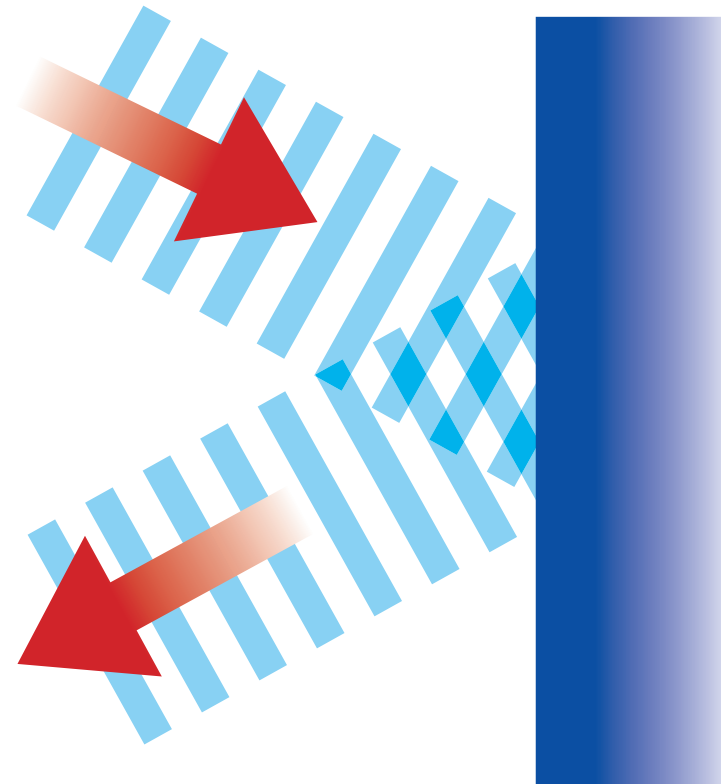

# Wave Interactions

## REFRACTION

Wave passes through a material and bends.

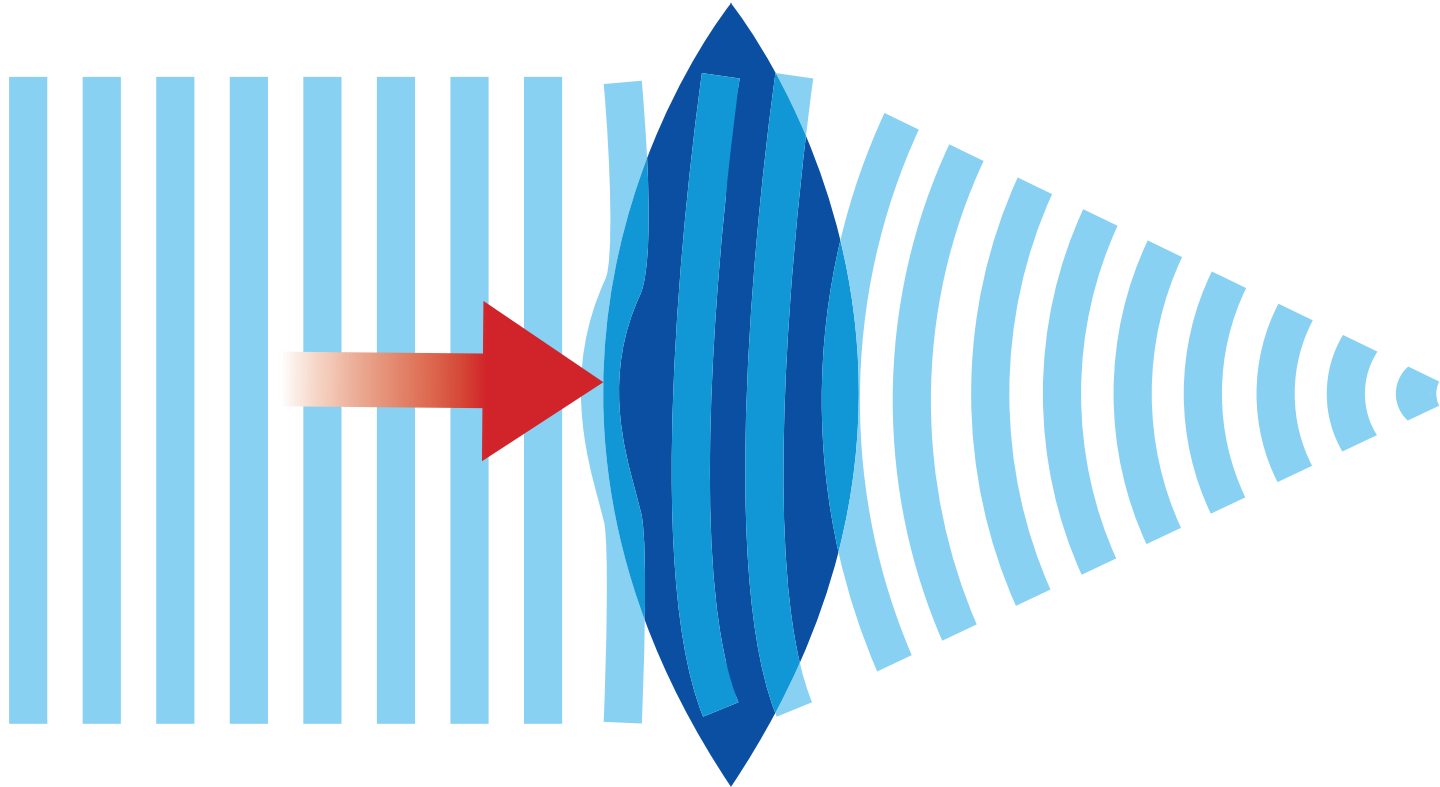

# Constructive Interference

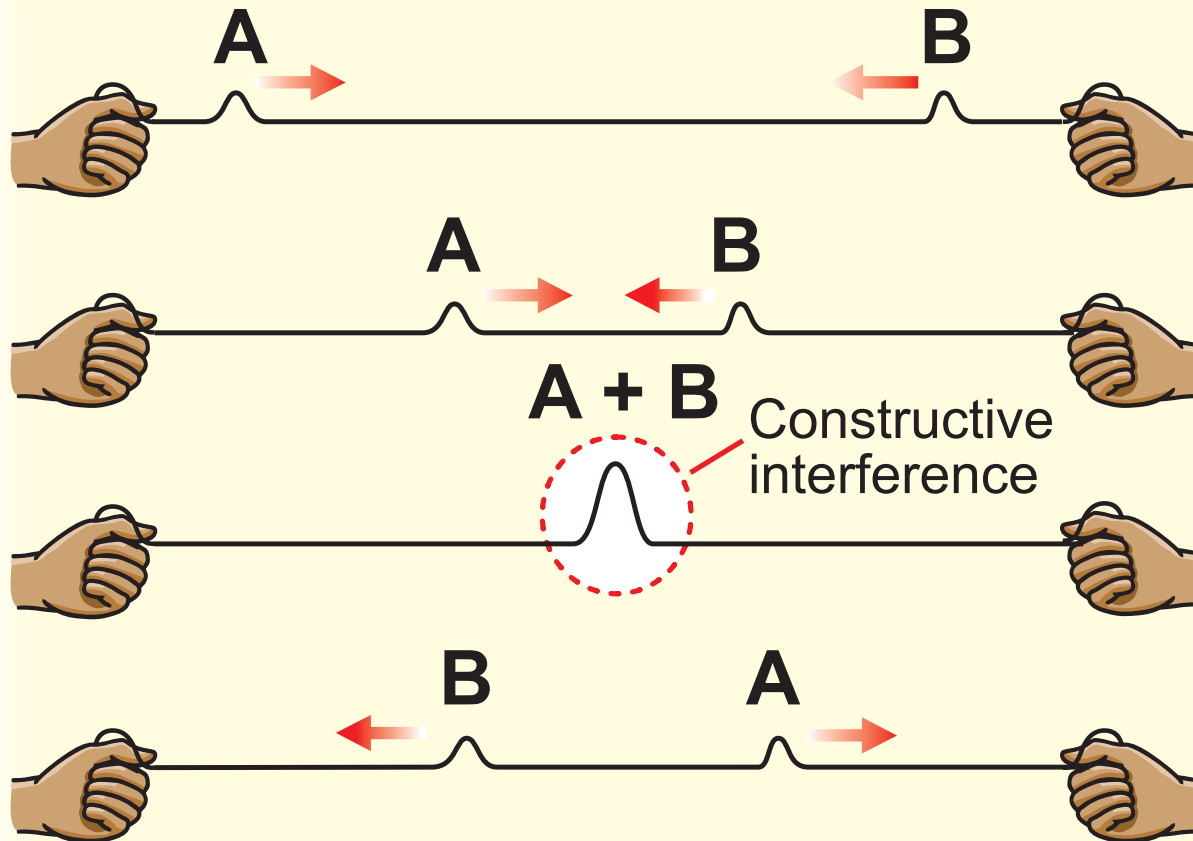

Two wave pulses that are in phase can add up to make a single, bigger pulse when they meet.

# Destructive Interference

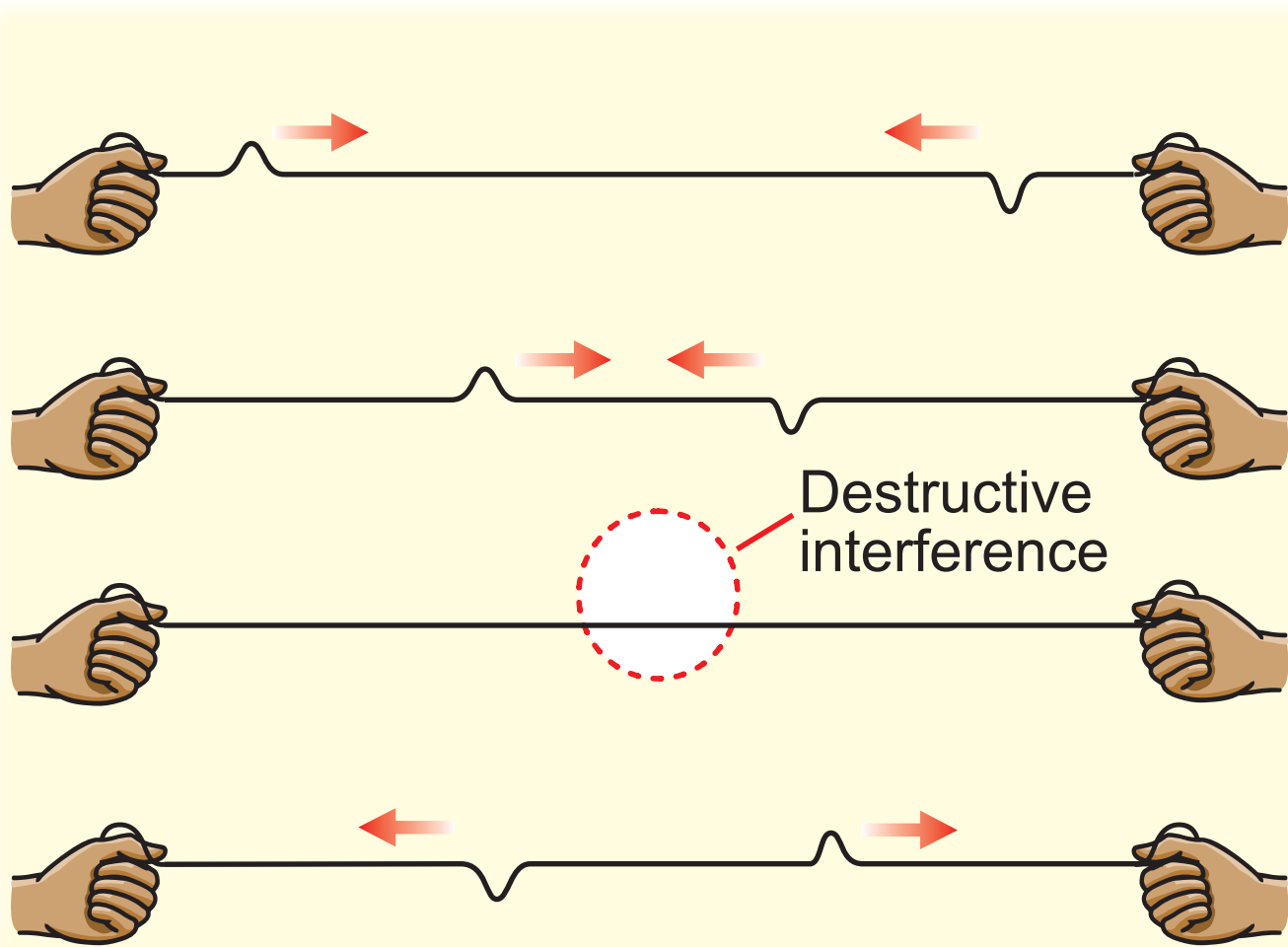

**Two equal wave pulses that are out of phase will subtract when they meet. The upward movement of one pulse can exactly cancel the downward movement of the other.**

# The Superposition Principle

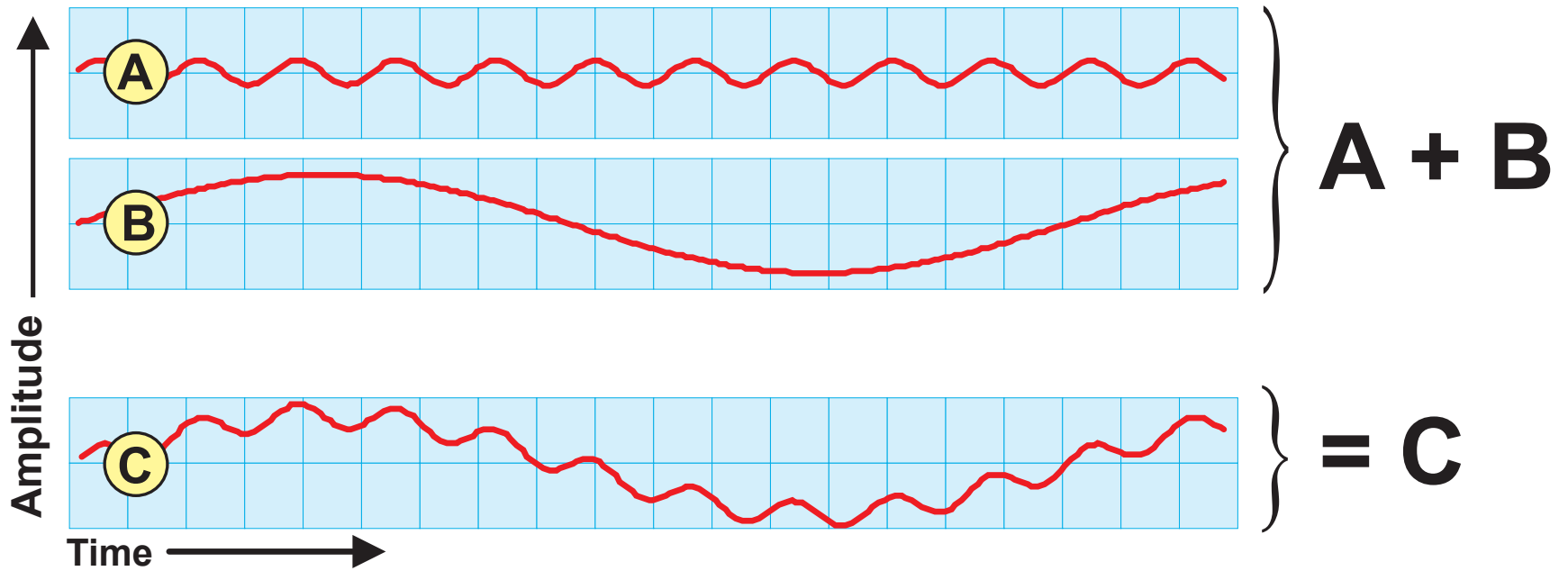

# The Doppler Effect

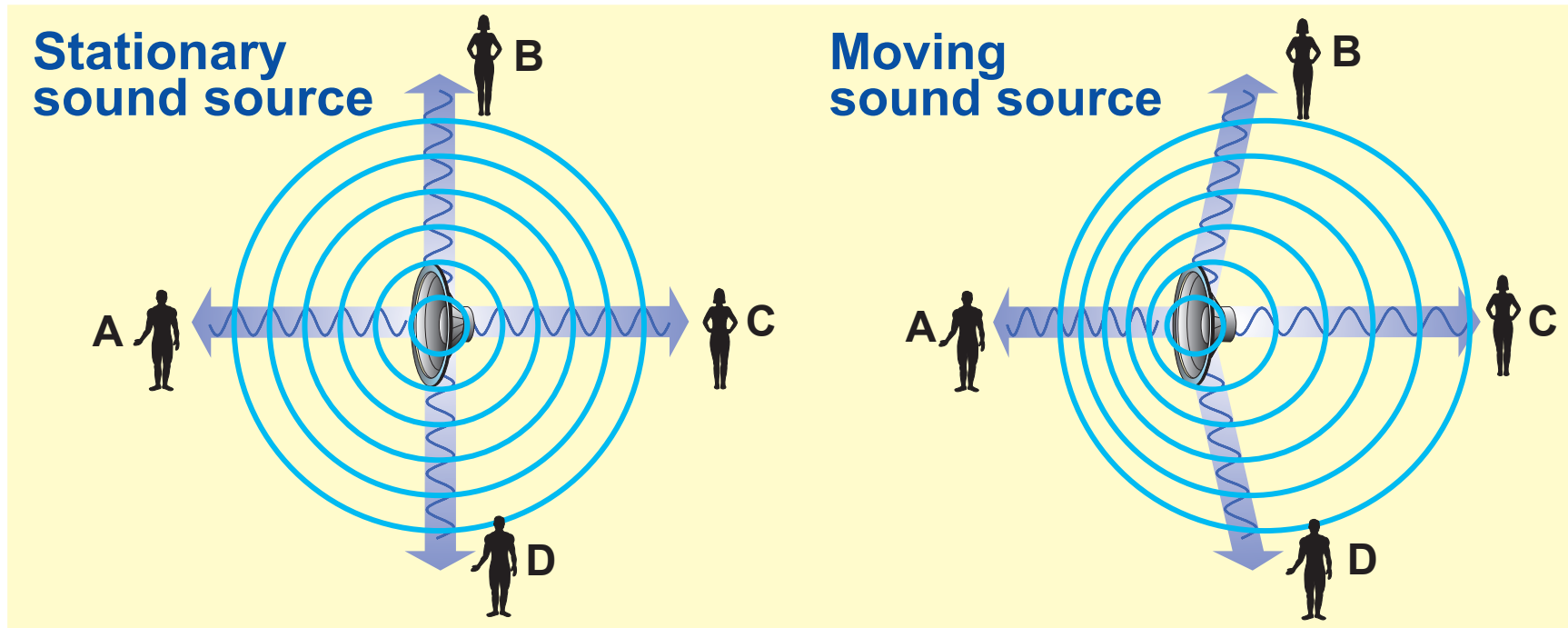

# Sound Waves

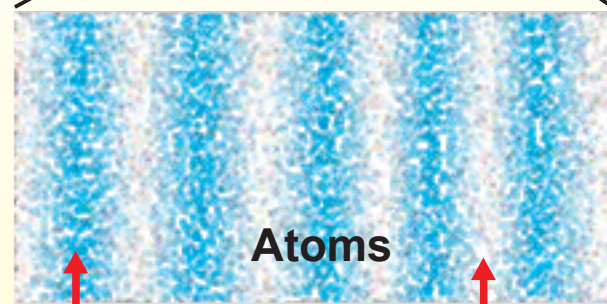
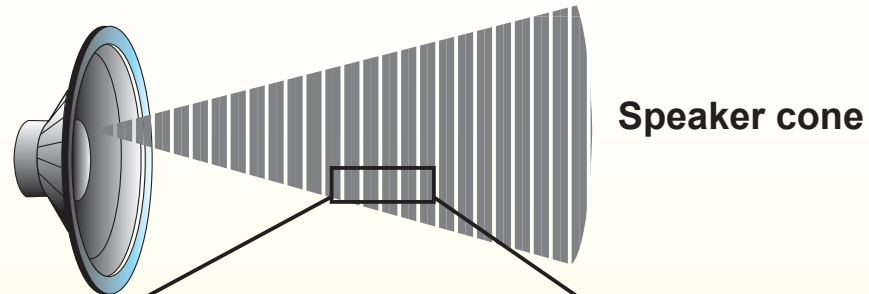

What a sound wave might look like if you could see the atoms.

Higher pressure



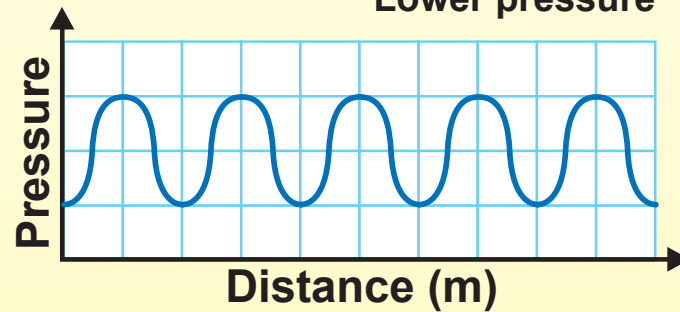



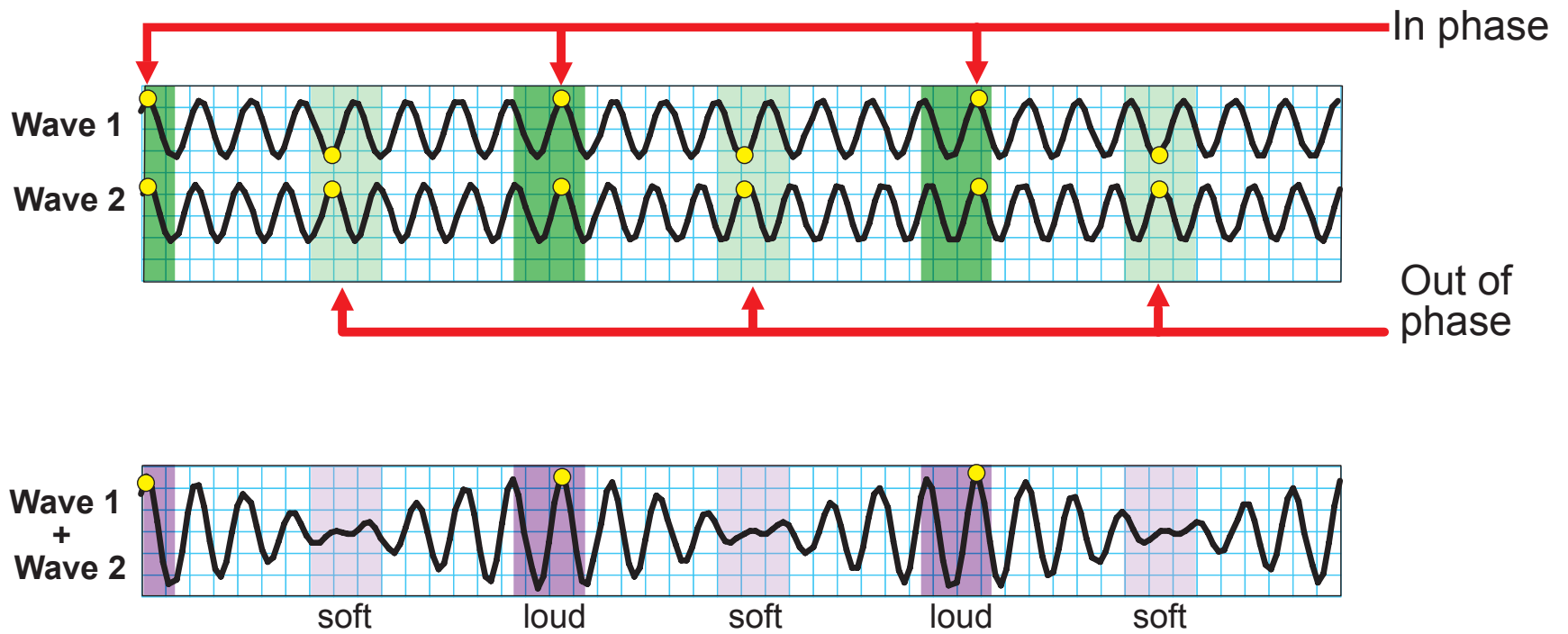

Lower pressure

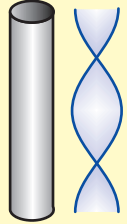
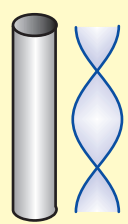
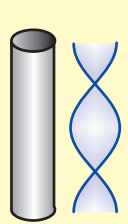
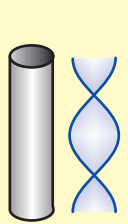
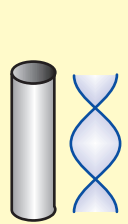
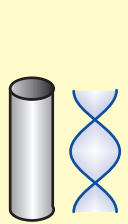
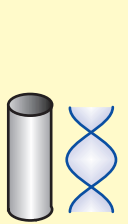
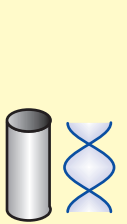

# Why We Hear Beats

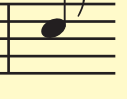

# The C Major Musical Scale

<b>C major scale</b>								
								
<b>Note</b>	<b>C</b>	<b>D</b>	<b>E</b>	<b>F</b>	<b>G</b>	<b>A</b>	<b>B</b>	<b>C</b>
<b>Frequency (Hz)</b>	264	297	330	352	396	440	495	528
<b>Ratio to C-264</b>	1/1	9/8	5/4	4/3	3/2	5/3	15/8	2/1
	$\left(\frac{264}{264}\right)$	$\left(\frac{297}{264}\right)$	$\left(\frac{330}{264}\right)$	$\left(\frac{352}{264}\right)$	$\left(\frac{396}{264}\right)$	$\left(\frac{440}{264}\right)$	$\left(\frac{495}{264}\right)$	$\left(\frac{528}{264}\right)$

# Standing Waves

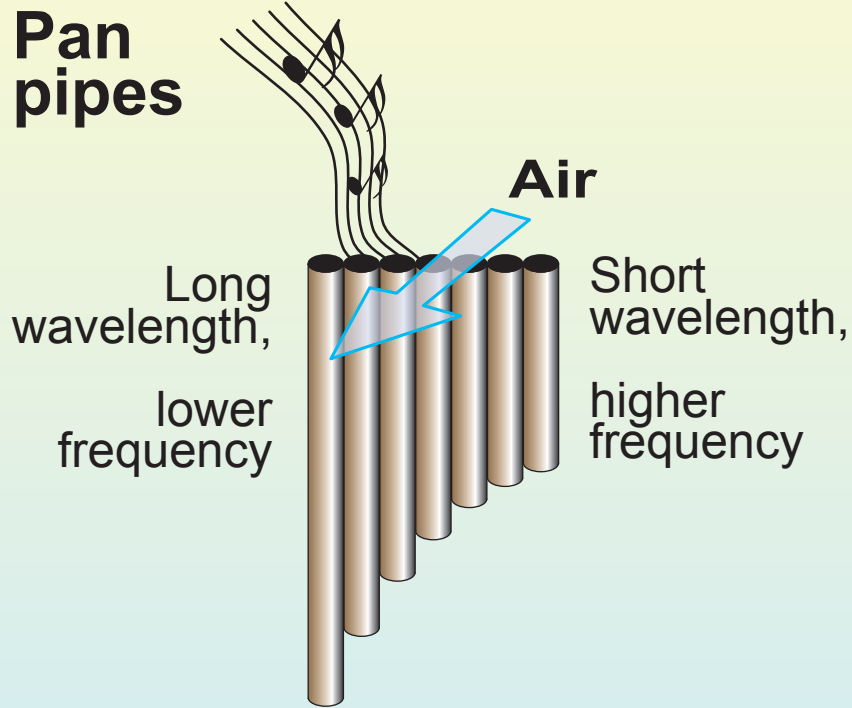

## Standing wave in a pan pipe

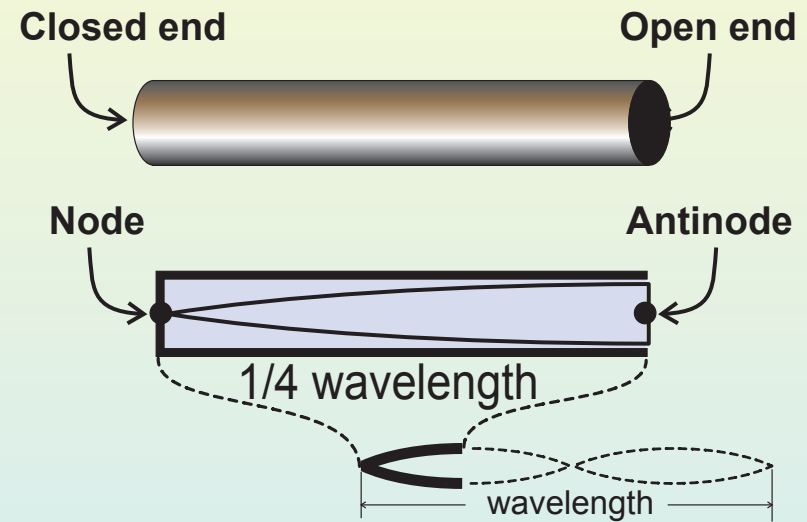

**The wavelength of the fundamental is four times the length of the pipe.**