

# Light Intensity

The inverse square law for intensity

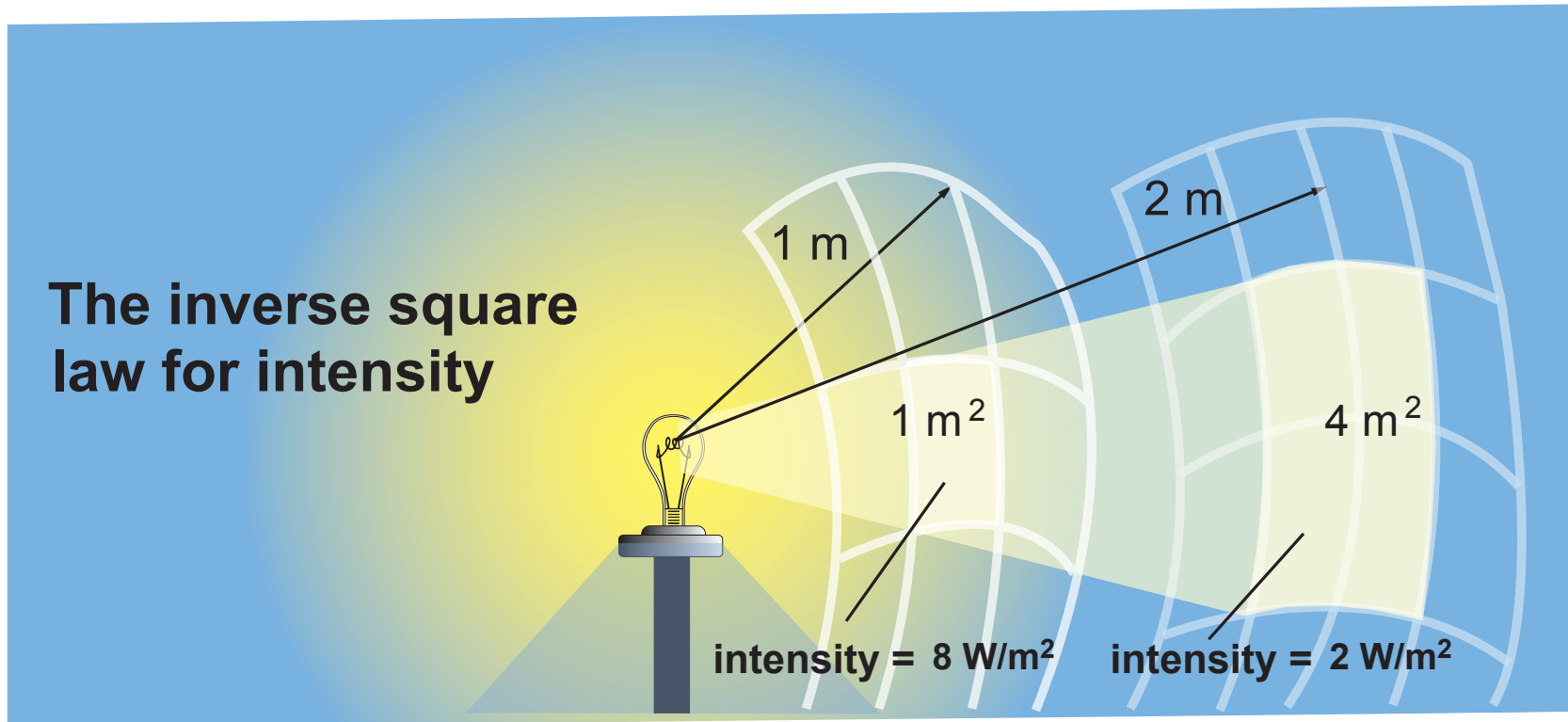

# Additive and Subtractive Primary Colors

## The additive primary colors

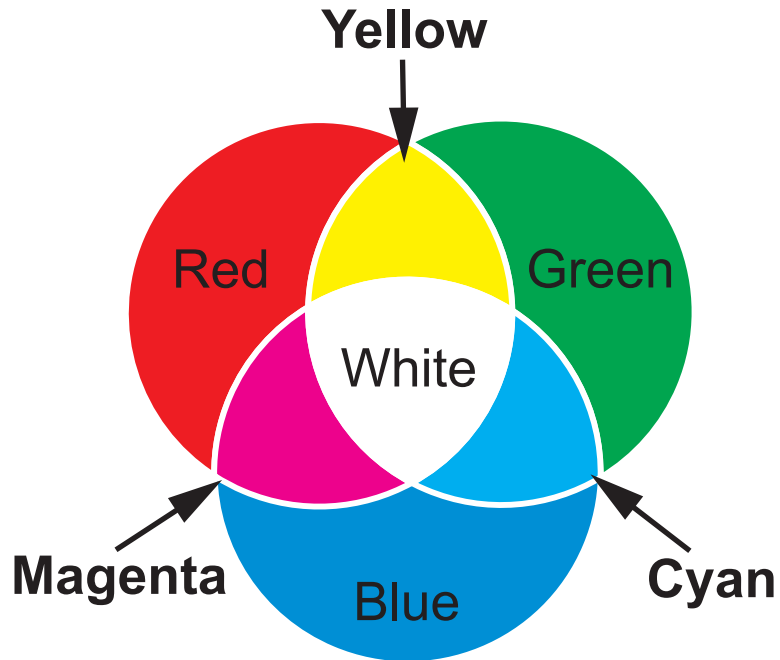

White = red + green + blue  
Yellow = red + green  
Magenta = red + blue  
Cyan = blue + green

## The subtractive primary colors

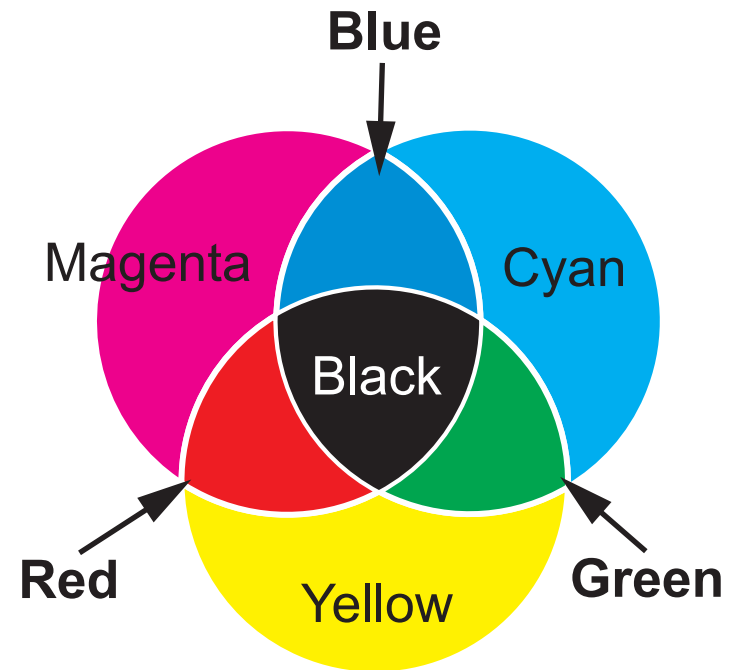

Black = magenta + yellow + cyan  
Red = magenta + yellow  
Green = cyan + yellow  
Blue = magenta + cyan

# Colors and Frequencies

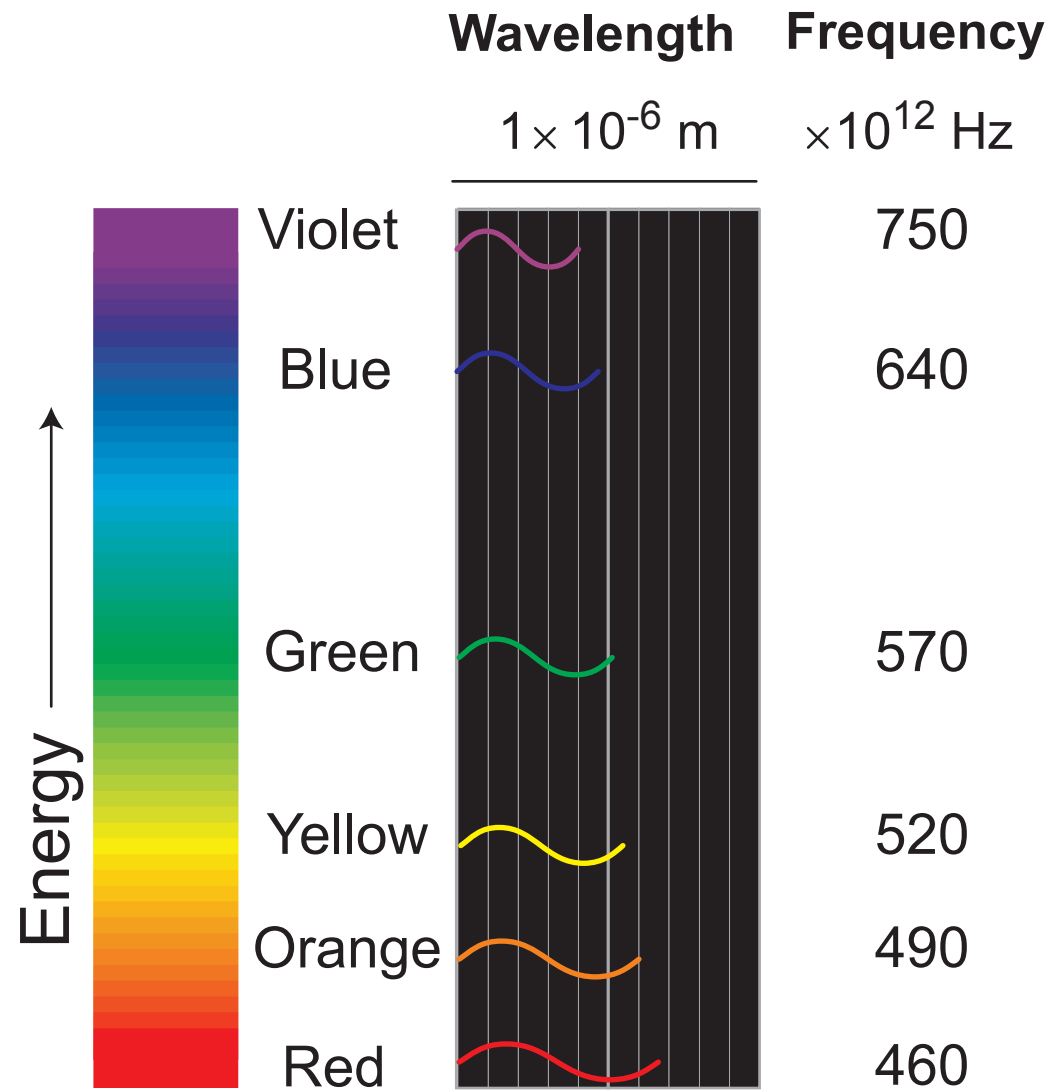

# CMYK Pigments

To make	Mix	Because	White light
Red 	Magenta and yellow  + 	Magenta absorbs green Yellow absorbs blue Red gets reflected	
Blue 	Magenta and cyan  + 	Magenta absorbs green Cyan absorbs red Blue gets reflected	
Green 	Cyan and yellow  + 	Cyan absorbs red Yellow absorbs blue Green gets reflected	

# The CMYK Color Process

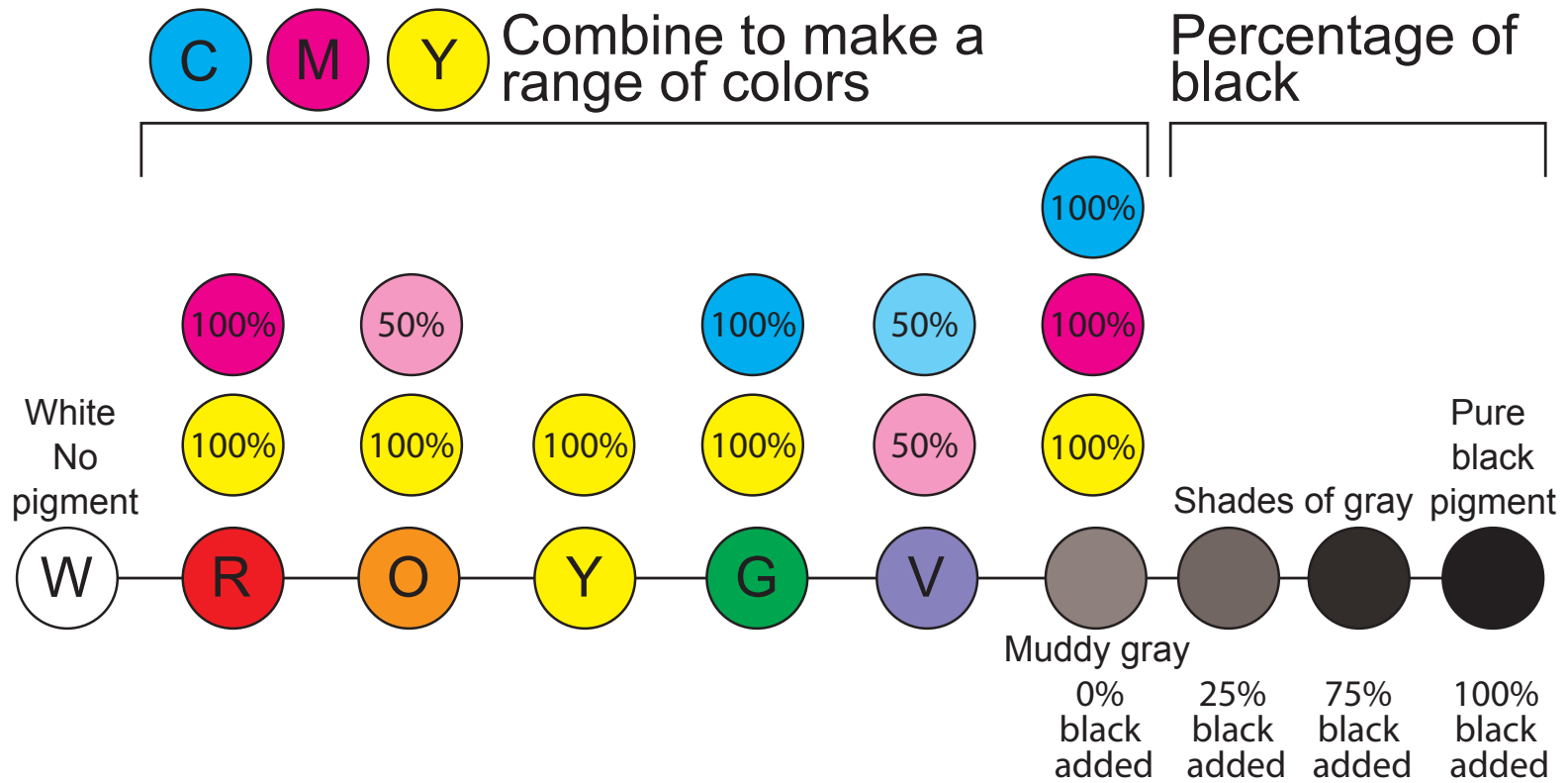

# The RGB Color Process

Dot color on TV monitor	The color you see on the TV monitor					
	Black	White	Red	Yellow	Green	Blue
Red	off	on	on	on	off	off
Green	off	on	off	on	on	off
Blue	off	on	off	off	off	on

# Law of Reflection

Ray diagram

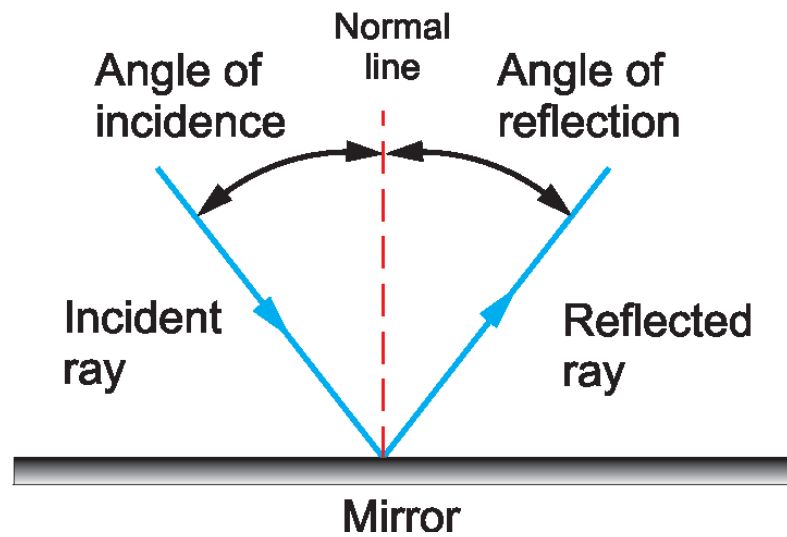
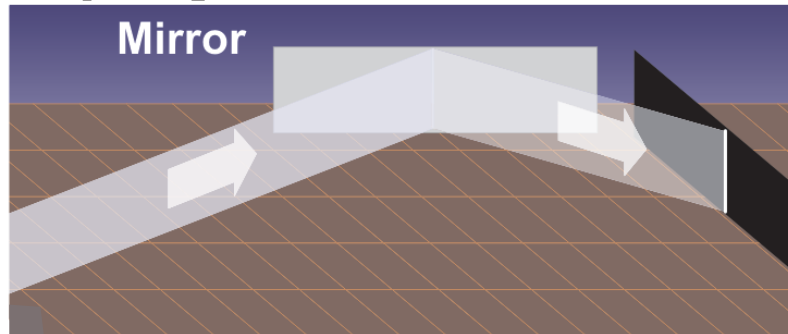

# Index of Refraction

Material	Index of refraction ( $n$ )
Vacuum	1.0
Air	1.0001
Water	1.33
Ice	1.31
Glass	1.5
Diamond	2.42

Light path	How light is refracted
High $n$ to low $n$	Bends away from normal
Low $n$ to high $n$	Bends toward normal

# Refraction

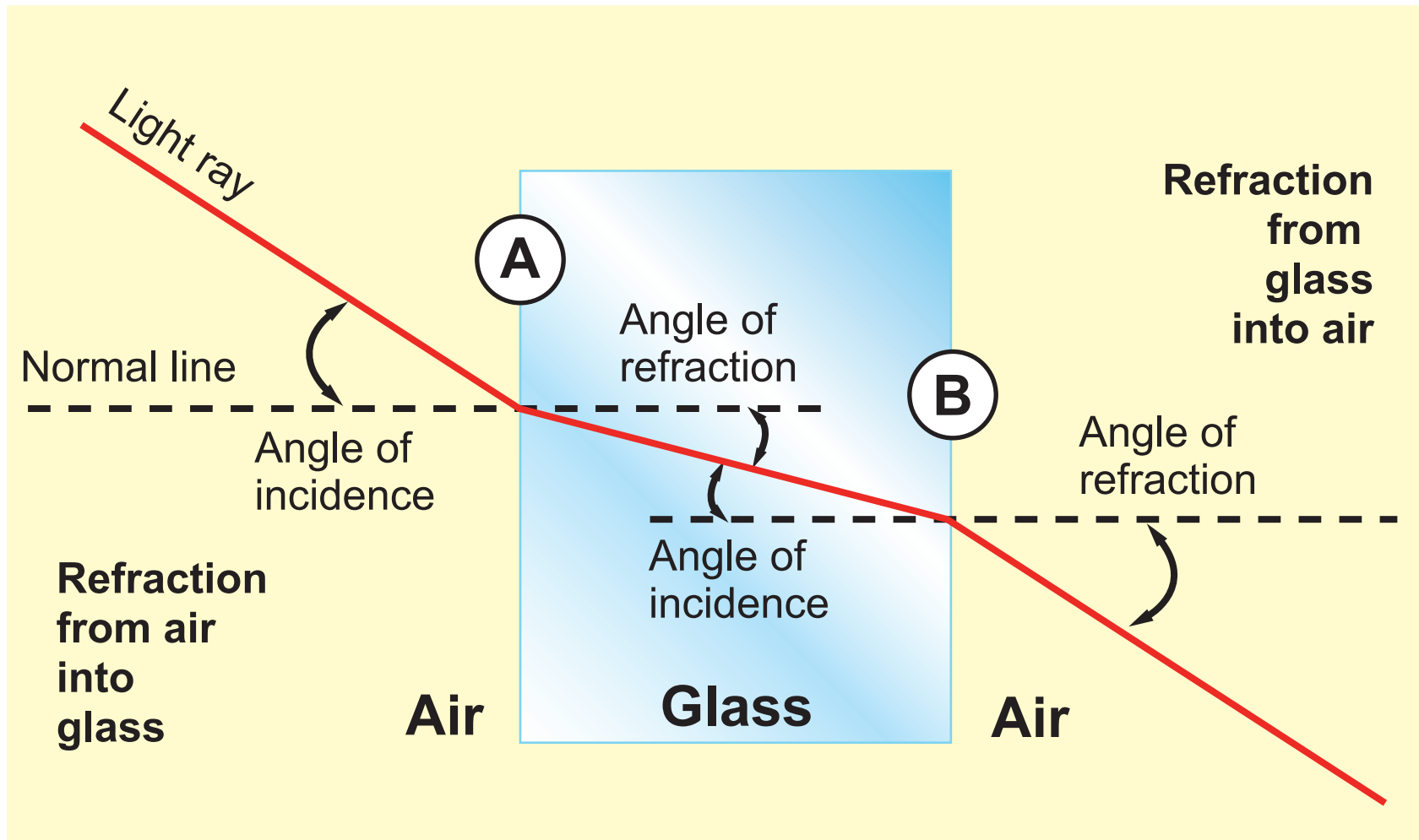

# Images

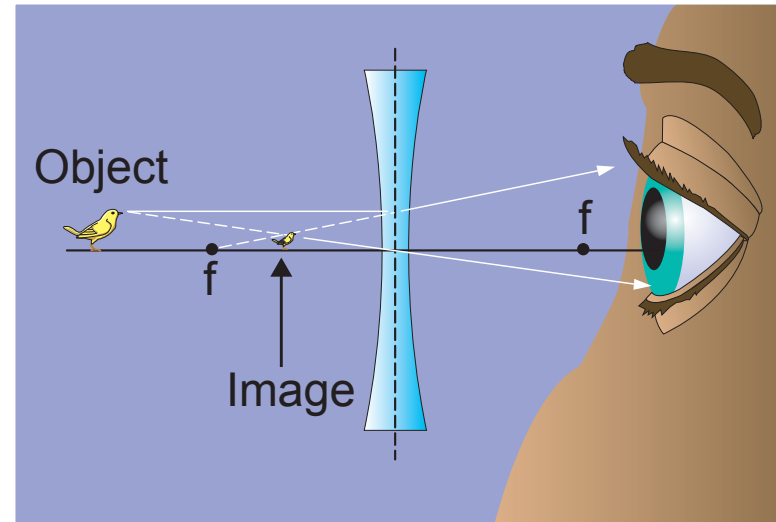
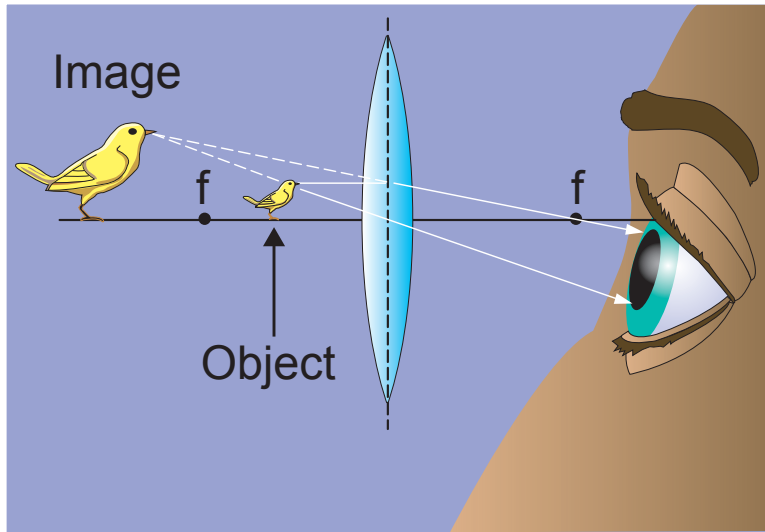

Lens	Position of object	Image
Converging	Beyond the focal length	Real
Converging	Inside the focal length	Virtual and larger
Diverging	Anywhere	Virtual and smaller than object

# Lens Definitions

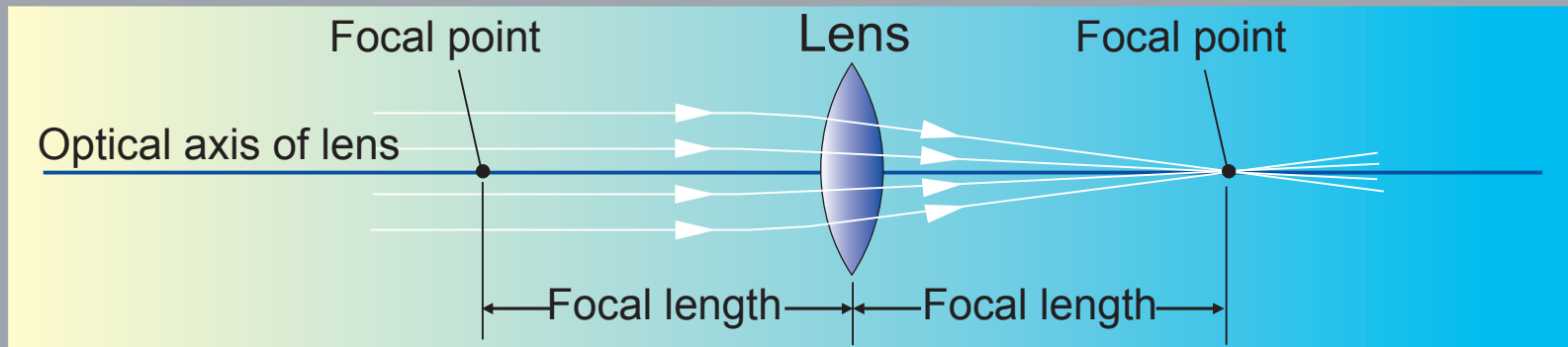

# Lenses

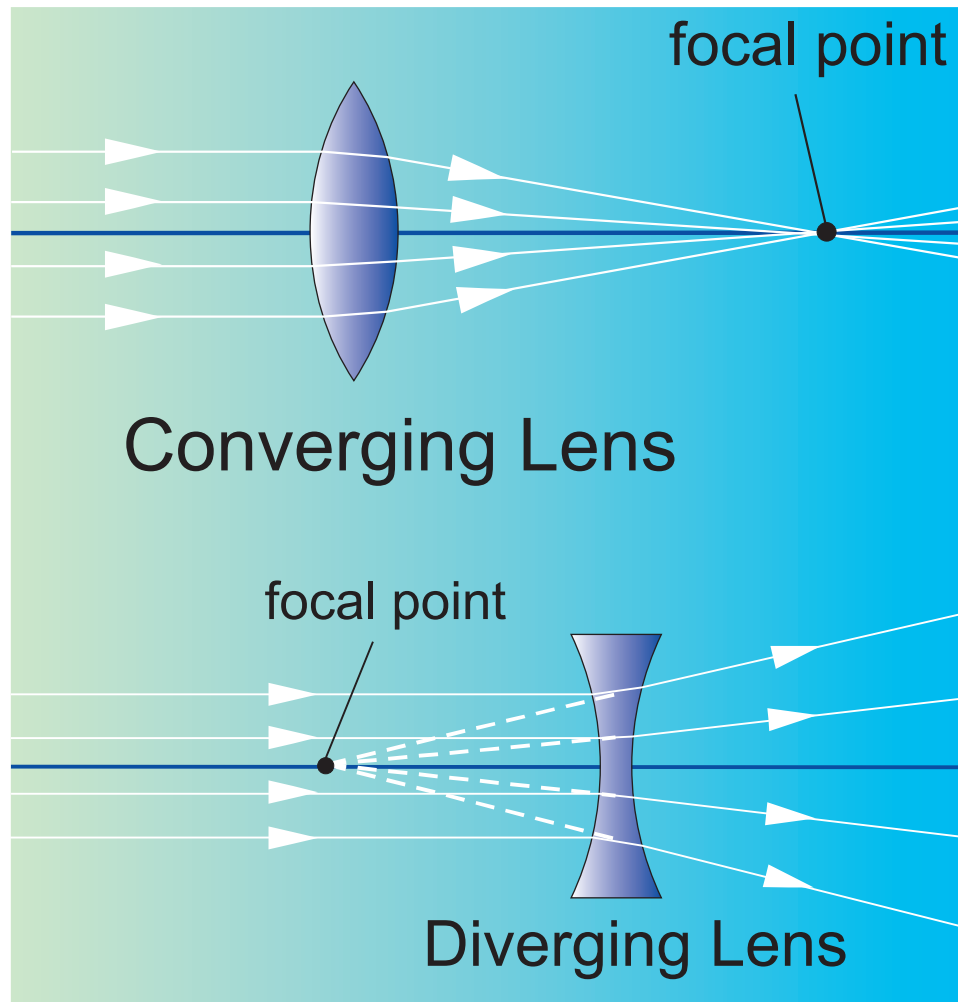

# Drawing a Ray Diagram

Setting up

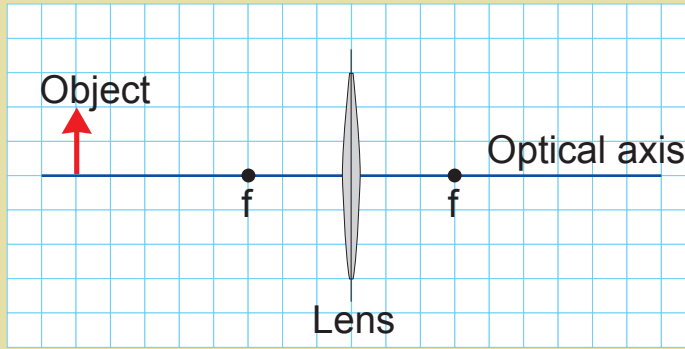

Step 1 Drawing the first ray

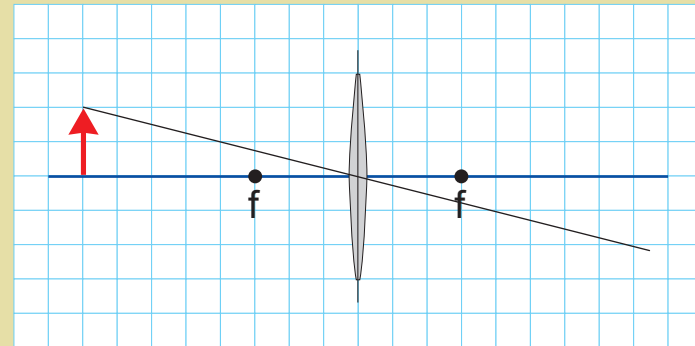

Step 2 Drawing the second ray

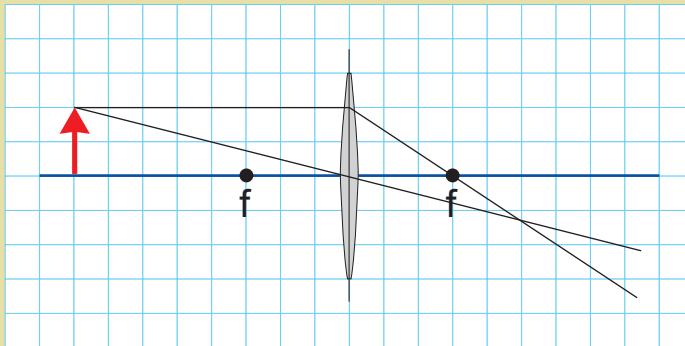

Step 3 Drawing the third ray

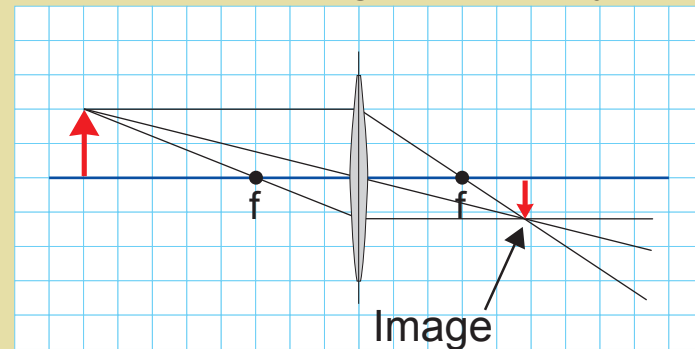

# Electromagnetic Spectrum

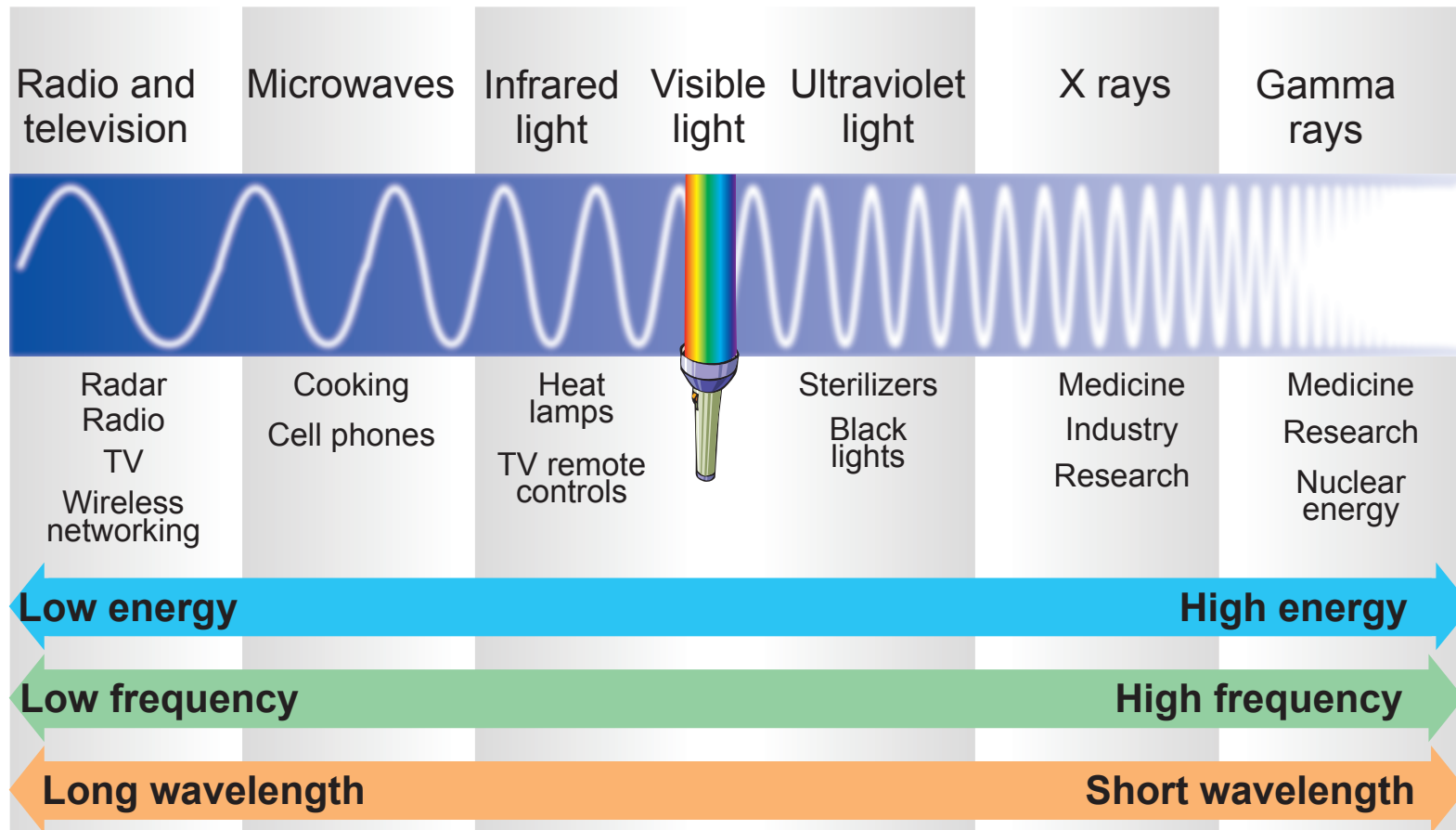

# The Speed of Light

(relationship between frequency and wavelength)

$$\text{Speed of light } (3 \times 10^8 \text{ m/sec}) \rightarrow c = f \lambda$$

Wavelength (m)  
↓  
↑  
Frequency (Hz)

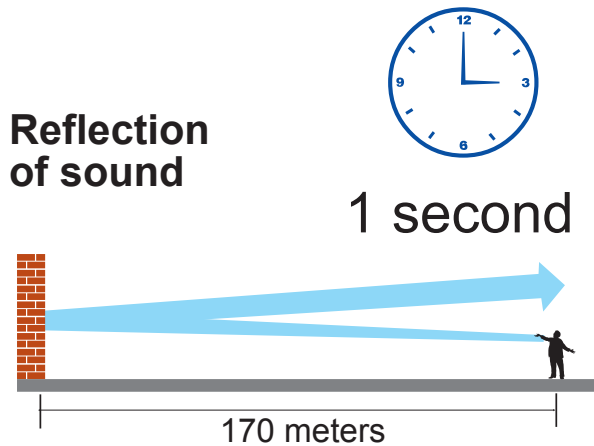

**Speed of sound**  
340 m/sec

**Speed of light**  
300,000,000 m/sec

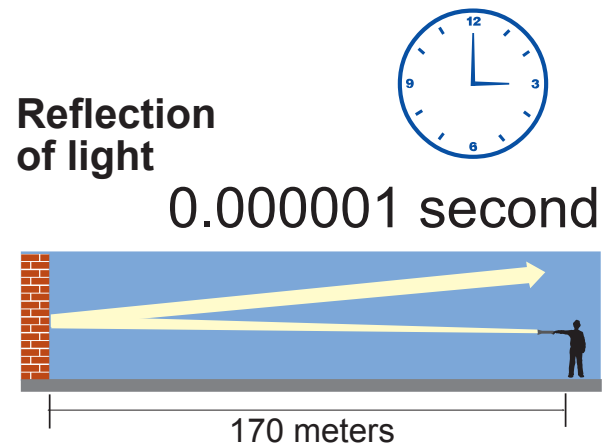

# The Double Slit Experiment

What you might expect ...  
*(if light were NOT a wave)*

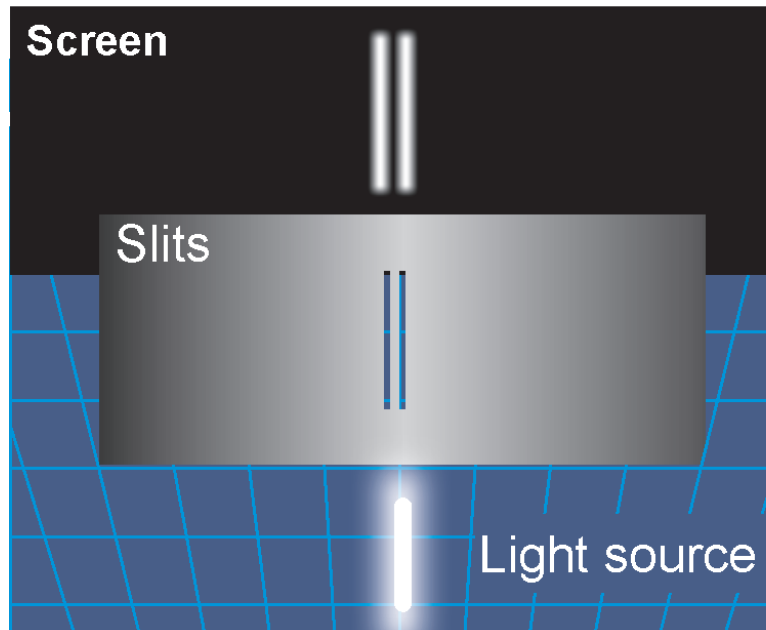

What you actually observe  
*(because light IS a wave)*

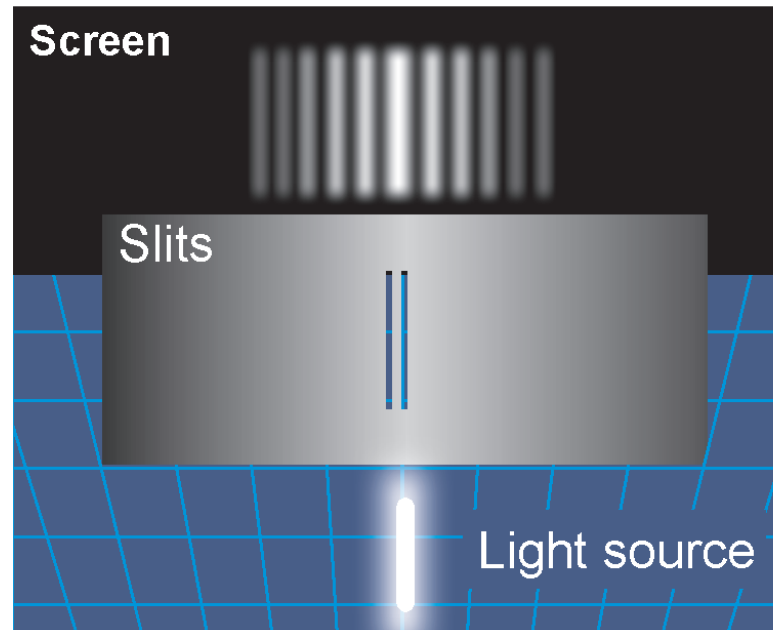

# The Interference of Light Waves

## Constructive Interference

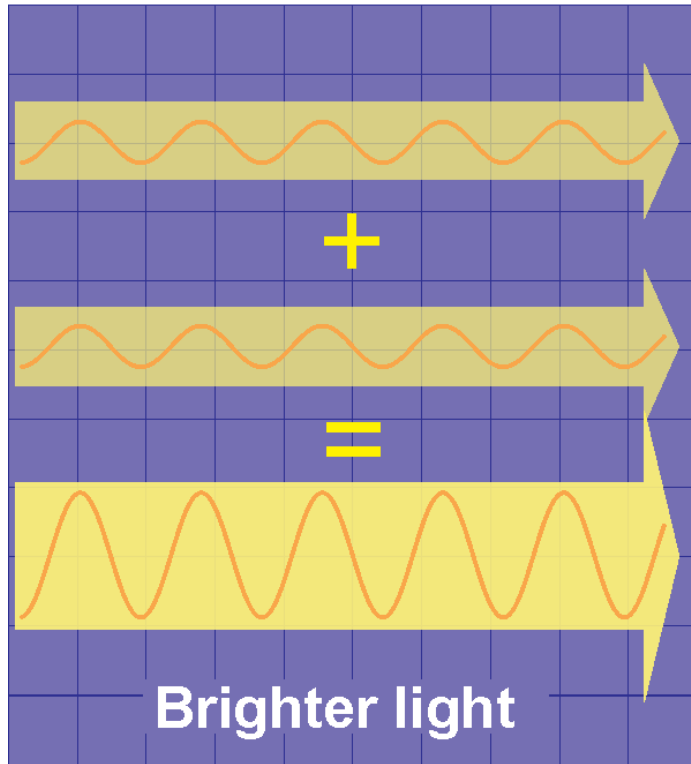

## Destructive Interference

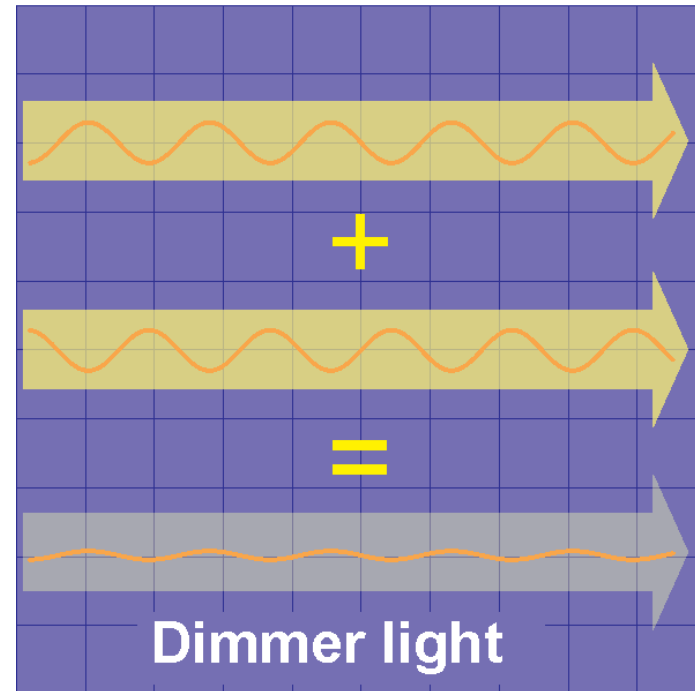

# Photons

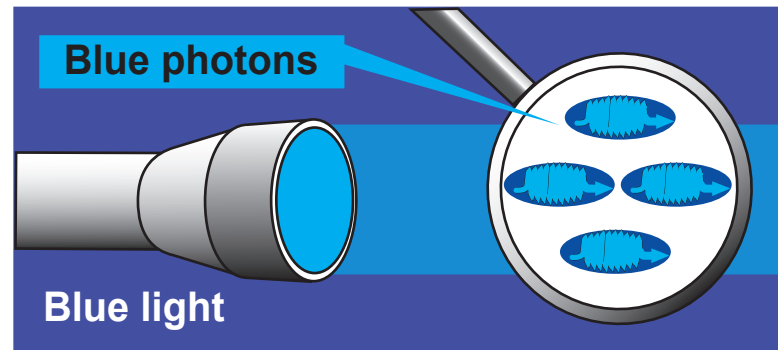
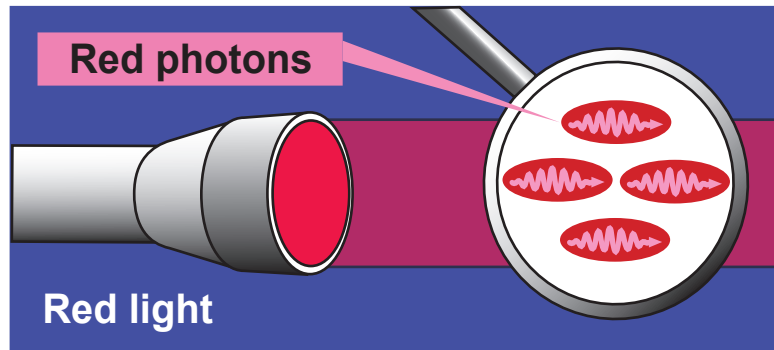

Blue photons have a higher energy than red photons.

Two ways to make the same intensity

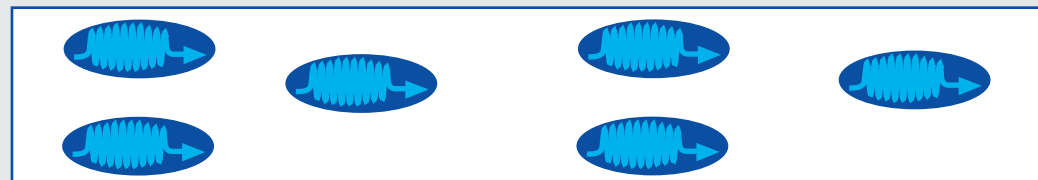
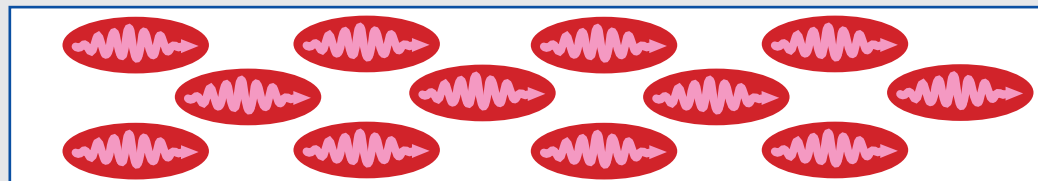

Fewer high-energy blue photons