

**cpo** science

# The Electric Motor Reference Guide



Copyright©2005 CPO Science

**cpo** science  
making it real.

# CPO Electric Motor Equipment Module

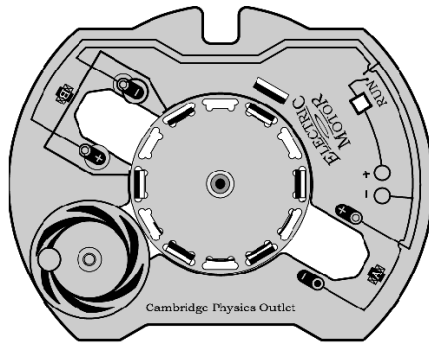

Electric motor

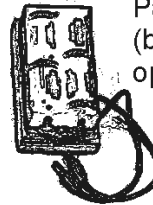

Battery Pack  
(batteries optional)

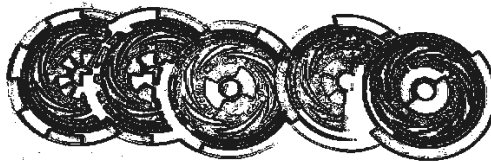

Commutator disks

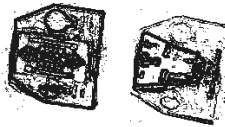

Electromagnet & coil modules



2 patch cords w/ 'banana' plugs

## Equipment Includes:

- 5 switch plates
- 1 electric motor body with permanent turn-crank
- 1 New high-output electromagnet motor modules (Black)
- 1 electromagnet generator modules (clear plastic)
- 12 labeled permanent ceramic magnets (not pictured)
- 1 battery pack
- 3 rubber bands (not pictured)
- 2 patch cords with banana plugs (1 red, 1 black)

# Why Learn About Electric Motors

Electric motors are everywhere. You find them in locomotives, washing machines, cars, tools, spacecraft, and anywhere else that we use powered machines. The principles illustrated by the CPO Electric Motor are common to all electrical machinery and even to the basic workings of electronic devices. Among the topics which can be explored with the Electric Motor, this list is just the start, the Electric Motor and the Digital Meter combined make up a complete self-contained laboratory for learning about electricity and magnetism. Below is a list of applicable topics:

- **Magnetism**
- **Permanent Magnets and Electromagnets**
- **Electric Circuits, Current and Voltage**
- **Series and Parallel Circuits**
- **Electrical Machines**
- **Electric Power, What is a Watt?**
- **Efficiency**
- **Design for Optimum Performance**
- **Rotational Motion**
- **Frequency and Harmonic Motion**

## About the Electric Motor/Generator

The Electric Motor teaches many concepts, including how electricity is generated. There are two types of electromagnet modules. The motor comes with one of each type. One is designed to function as an electric motor (the black one), as described in the following pages. The other module is made of clear plastic and has simple electromagnet coils. This clear electromagnet functions as a generator. It allows students to observe that spinning a disk of alternating magnets past a wire coil generates electricity.

The law of magnetic induction states that electric voltages will be generated whenever the magnetic field passing through a loop (or coil) of wire is changing. Spinning the rotor with magnets in it causes a changing magnetic field to occur in the steel pin, which is 'picked up' by the coil as electricity. The electricity can be up to a volt or two depending on the configuration of magnets and the speed at which the rotor is turned. Your meter can also measure the electric current, which can exceed 100 milliamps. There is not enough voltage or current to light a lamp, but almost any meter will effectively demonstrate that electricity is being created. The electricity (and your meter setting) will be AC, or alternating current since the magnetic field changes back and forth from north to south. All generators fundamentally make AC electricity, which can be converted to DC by circuits called 'rectifiers'

# About the Electric Motor/Generator (Cont'd)

The Generator module has banana plug connectors for attaching to a meter.

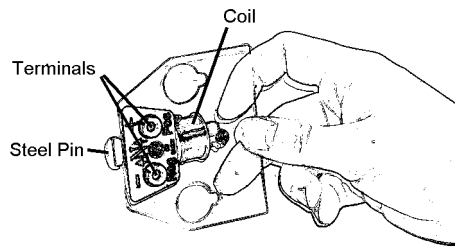

A meter (in AC mode) can be connected between the terminals of the generator module. More than one generator module can be connected to each other (and to a meter) in series or parallel. If two modules are used, the electricity can cancel itself out if the magnets are not properly arranged.

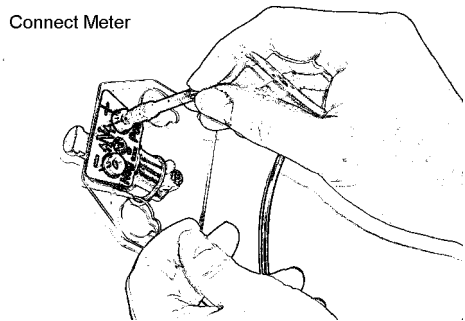

The crank is permanently attached to the body of the electric motor for use with generator activities.

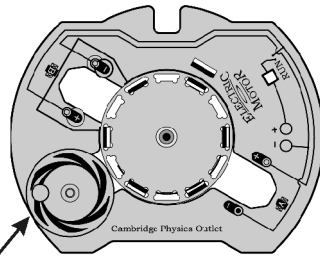

Motor Crank

A rubber band serves as the belt that connects the crank to the drive shaft at the center of the Electric Motor's rotor. You may want to attach a photogate and use the CPO Timer to see how the speed of the rotation affects the current and voltage produced by the generator. Disconnect the rubber band when you are not using the crank to drive the motor. (pictured with a prior version of the Electric Motor body).

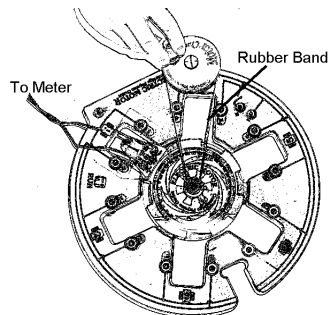

# The Permanent Magnets

Motors work by using magnetic forces to push and pull on other magnets. Two kinds of magnets are used in the Electric Motor. **Permanent magnets** create their own magnetic fields without electricity being supplied. There are 12 small ceramic permanent magnets supplied with the Electric Motor. These magnets have two **poles**. Magnetic poles follow the following rules:

**Like repels like**

**Unlike poles attract**

For example putting two north poles facing each other will cause the magnets to repel each other. The magnets that come with the motor are not like ordinary bar magnets in that they have the north and south poles on the faces rather than the ends (see drawing below). There are red and white stickers on the magnets to identify the north and south poles.

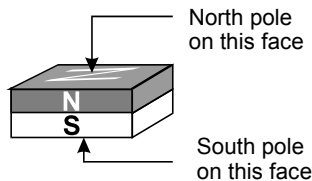

# The Electromagnets

**Electromagnets** use electric current to make the magnetic field. The simplest electromagnet uses a coil of wire, often wrapped around some iron or steel. The coil of wire creates a magnetic field, just like a bar magnet. The iron or steel amplifies the magnetic field created by the current in the coil. When current flows through the coil, the steel core becomes a magnet - which is a stronger magnet than the coil alone. The location of the north and south poles depends on the direction of the electric current.

## The Right Hand Rule

**When the fingers of your right hand curl in the direction of the current, your thumb points in the direction of the magnetic field.**

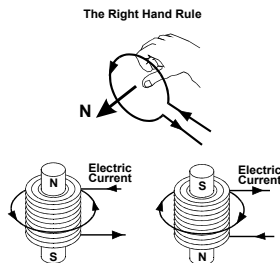

## The Electromagnets (cont'd)

The Electromagnet Module that comes with the motor has an electric eye switch that is used to change the direction of the current flowing in the coil of wire. There are LED's on the top of the magnet that indicate where the north pole is. When the electric eye is not blocked (see diagram on next page) the current flows in a direction such that the north pole of the magnet is at the front end of the Electromagnet Module. Blocking the beam causes the electronics in the module to reverse the direction of the current, putting the north pole at the back end, **and a south pole at the front.**

- 1 When the light beam is unbroken, the light shows that the north pole is at the front end of the electromagnet.

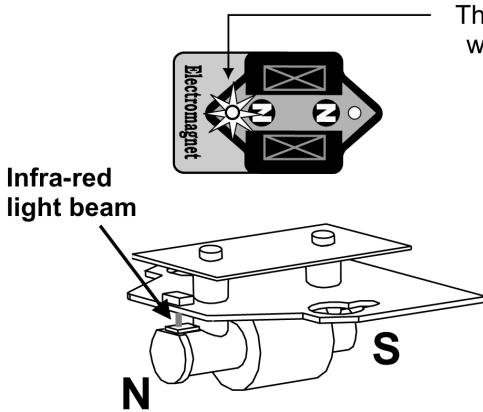

- 2 When the light beam is broken, the light indicates that the north pole is at the back end of the electromagnet, and the south pole is at the front end.

The light tells you where the north pole is.

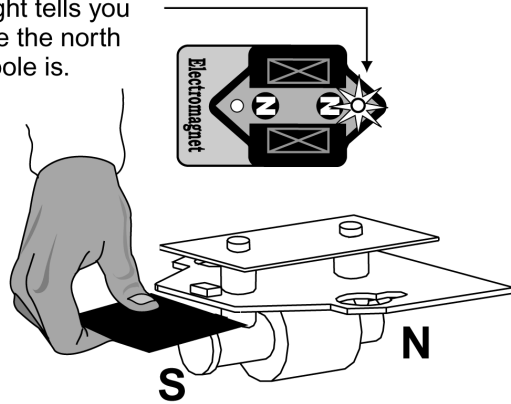

Blocking the light beam reverses the direction of the current in the electromagnet coil, which in turn reverses the magnetic poles.

# How Electric Motors Work

All electric motors use one or both of the two kinds of magnets just mentioned. Permanent magnets are useful because they create the magnetic field without needing any electricity. Electromagnets are necessary because the north and south poles can be controlled (or switched) as needed by the direction of the current in the coil.

The picture below shows the rotor of the Electric Motor with twelve magnets inserted so that the north and south poles alternate. The electromagnet pushes and pulls on the permanent magnets in the rotor. If the pushes and pulls happen at the right places the rotor will spin and the motor will work. The key to an electric motor is to make the electromagnets change polarity at the right position of the rotor. The diagram shows the electromagnet switching from north to south as a south pole in the rotor passes by. If the electromagnet switches *just as the permanent magnet passes by*, the force acting on the rotor will always cause it to rotate in the same direction.

The key to making an electric motor is to switch the polarity of one or more electromagnets to alternately push and pull the magnets in the rotor. In the CPO Electric Motor the electromagnets are arranged around the outside of the rotor. The arrangement of stationary electromagnets is often called the **stator** because it creates a static magnetic field that interacts with the moving field of the rotor. Some motors use electromagnets in both the rotor and the stator.

Electromagnets can be made much more powerful than permanent magnets and copper wire is considerably less expensive than the rare earth materials used in the strongest permanent magnets. The **AC** or **alternating current** motors in household appliances and most machinery use only electromagnets. Since the direction of AC current reverses every 60th of a second, the switching of the electromagnets in an AC motor is not as easy to follow as in a **DC**, or **direct current** electric motor. In a DC motor the direction of the current coming into the motor is always fixed. The positive and negative terminals do not alternate as they do with AC current.

Reversing the current in the electromagnets is usually done with a rotating switch called a **commutator**. Conductive carbon **brushes** bring the current into the motor and the commutator switches the current into the windings of the coils. The commutator looks like a series of copper bars that rotate with the shaft of the motor. If you open up almost any motor, AC or DC, you will find brushes and a commutator. Since the brushes slide on the commutator and carry large electric currents they are susceptible to failure. Most motors require the brushes to be replaced periodically. It is possible to make an AC brushless motor by **inductively** driving the current in the rotor. The best AC motors are made this way but it takes more copper wire and steel to do it and therefore makes a heavier and more expensive (but quieter) motor.

The CPO Electric Motor is technically a **brushless DC permanent magnet** design. The optical switch in the Electromagnet Module allows the current to be reversed without needing brushes or commutator. This technology reduces friction and makes it possible to build many different motor designs on the same chassis. From 2 to 12 permanent magnets and 1-6 electromagnets can be combined to make a working motor.

**Permanent Magnets**

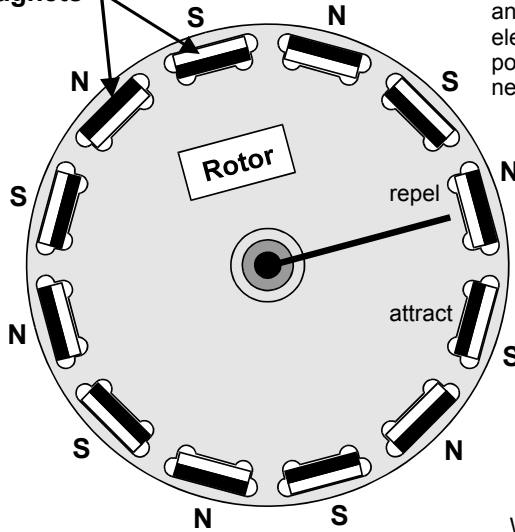

When the rotor is at this angle the north pole of the electromagnet repels a north pole in the rotor and attracts the next south pole.

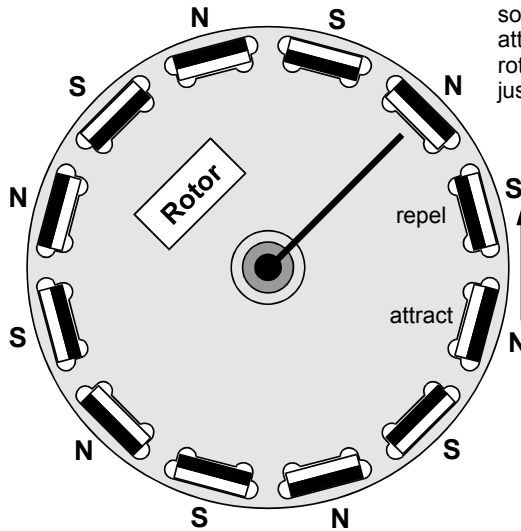
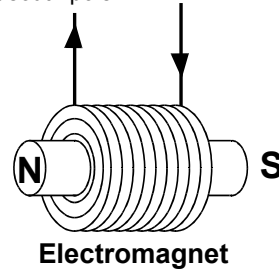

When the rotor rotates so that the south pole passes the electromagnet the current must switch. The (now) south pole of the electromagnet attracts the next north pole in the rotor and repels the south pole that just passed.

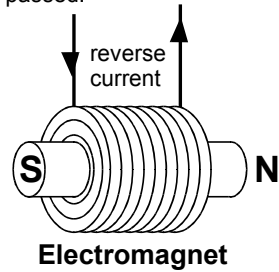

## The Switching Plates

The rotor in the Electric Motor has places where you can put up to 12 magnets. You can get to the magnets by removing the big nut on the shaft and lifting off the **switch plate**. The picture below shows where things are. The Electromagnet Modules have to be removed (or slid back) to get the switch plate out. Loosen the metal thumb nuts (just a little) to move the Electromagnet Modules.

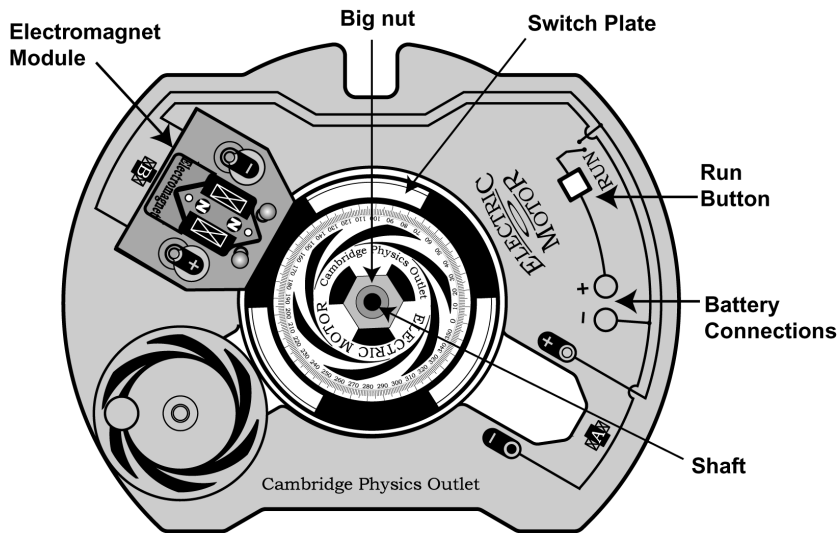

The picture shows the rotor with the switch plate on. On the following page, is a diagram of the rotor without the switch plate. Use an extra magnet or the big nut or anything else magnetic to pull the magnets out.

The Electromagnet Modules push and pull on the magnets in the rotor and make the motor spin. We know that the electromagnets must switch north and south poles every time a magnet passes by to make the rotor keep spinning in the same direction. Making this happen at the right place on the rotor is what the **switch plates** are for.

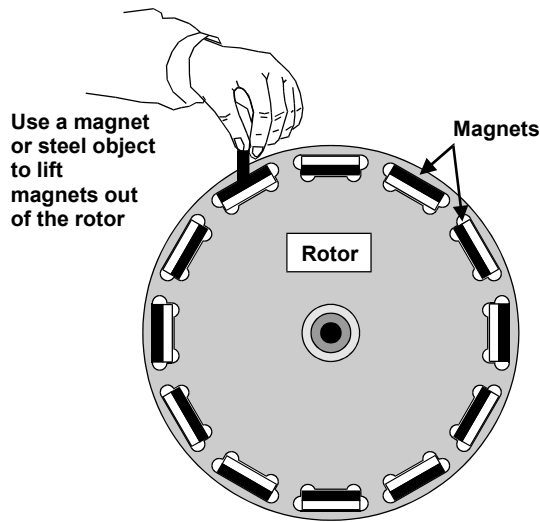

Find the 4-pole switch plate. This one has two black sections and two clear sections around the outer rim. The switch plate spins with the rotor and the black and clear parts around the rim switch the electromagnet modules! When there is a black segment under the electric eye, the north pole of the electromagnet is pointed *away* from the rotor. When there is a clear segment in the electric eye the light beam passes right through and the north pole of the electromagnet is pointed *towards* the rotor. We call the pink plate a **4-pole switch** because there are four places around the rim where there is a transition from black to clear. This plate makes the electromagnet reverse directions four times for each rotation of the switch plate.

4 Pole Switch Plate

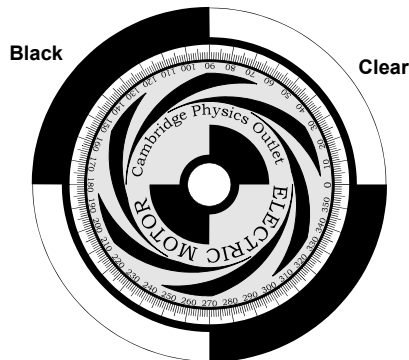

To make a working electric motor with the 4-pole switch plate you will need 4 magnets. The magnets should be arranged so that the north or south poles alternate as shown in the diagram. The alternation is necessary so that the electromagnets can pull then push each successive magnet in the rotor with the fewest number of switching cycles.

Remember that the electromagnet must switch as the magnet passes by. This means that the switch plate must be aligned with the magnets as shown. Finger-tighten the big nut (with the plastic washer underneath) to secure the switch plate once you have it aligned with the magnets.

Arranging the magnets for a 4 pole motor

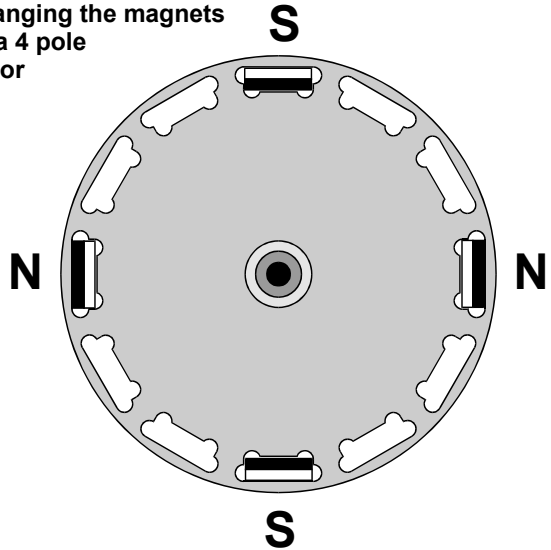

With the switch plate snug under the nut, and the four magnets aligned with the clear/black transitions, the motor should be ready to work. Put two Electromagnet modules opposite each other. To make the electrical connections, the Modules must be pushed all the way forward and the metal thumb nuts tightened finger tight. It might be necessary to lift the Electromagnet Module slightly to rest on top of the small brass terminal rings that stick up from the wooden base. Do not over-tighten the thumb nuts, only slight pressure is required to make electrical contact.

Connect the battery pack with the positive (red) and negative (black) wires in the corresponding positive (+) and negative (-) sockets on the motor. Push the RUN button and see what happens. You may have to give your motor a spin to get it started.

You can use two electromagnet modules and five different switch plates. This means there are (at least) 10 different designs of motor that you can build. **Not all will work!!!** We intentionally made one plate (the 8 pole) that does not work well because it requires 8 evenly spaced magnets and there are only 12 spaces. You can't factor 8 into 12 evenly so the students will have a tough time making the 8-pole switch plate work.

The diagrams below show the configuration for several working variations. For these designs the motor will spin (sometimes slowly) with a single electromagnet.

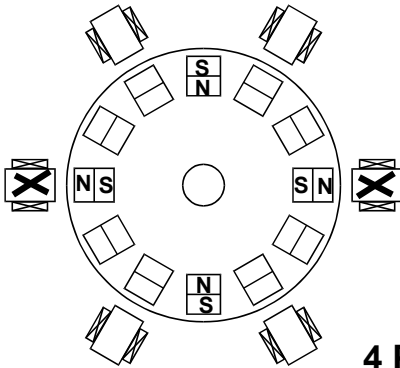

**4 Pole Design**

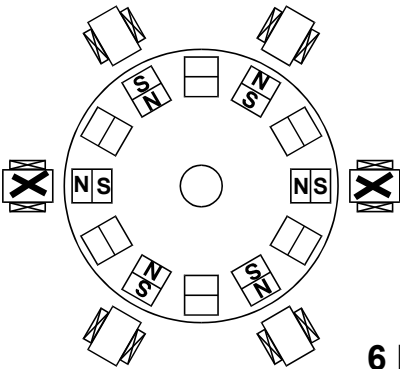

**6 Pole Design**

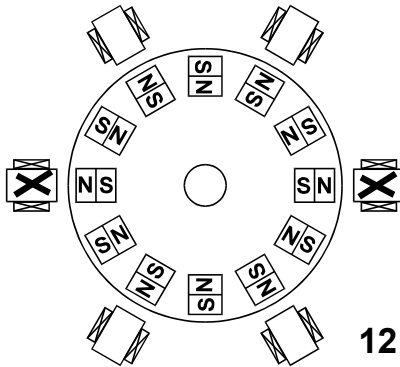

**12 Pole Design**

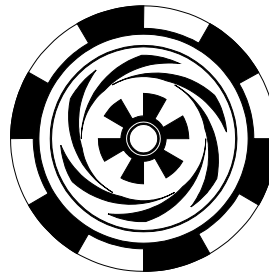

## Connecting the four-pole electric motor

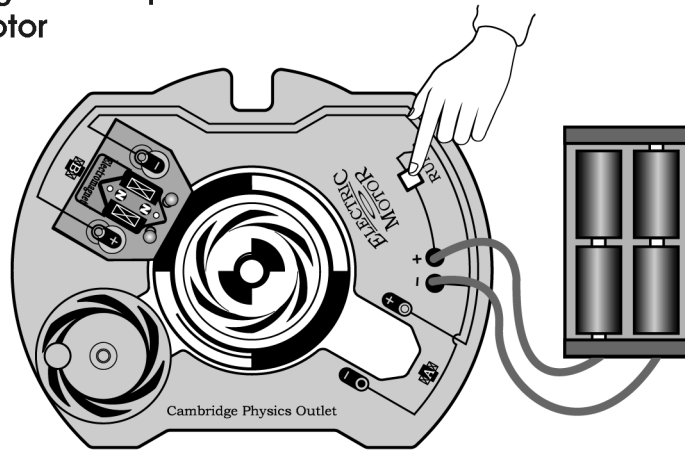

## Measuring the Speed of the Motor With the CPO Timer

When building a new machine part of the process is to try and build the best possible design given the materials and constraints. One way to compare different designs for the Electric Motor is to measure the speed of the rotor and try to design for the highest speed. The speed of the motor is measured with the Timer and Photogate. Attach the photogate to the motor in the slot at the top as shown in the diagram. If the photogate is pushed in as far as it will go, the black parts of the switching plate will break the light beam in the photogate. By measuring the frequency at which the beam is broken it is easy to determine the rotation speed (rpm) of the motor.

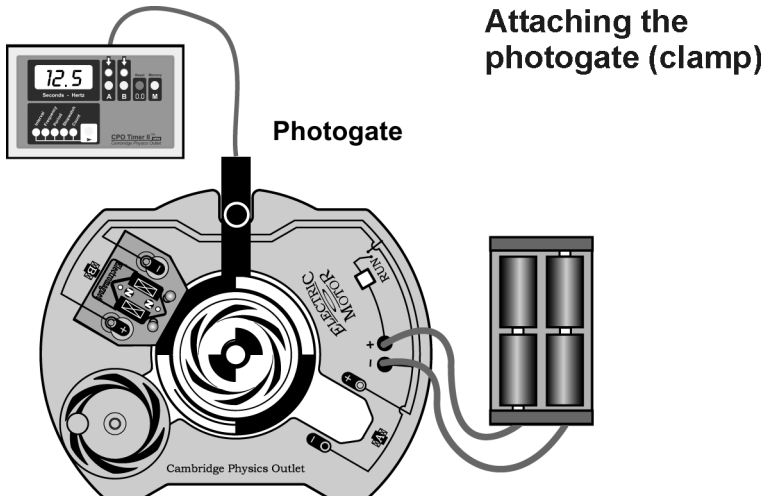

## Using Frequency Mode

In frequency mode the Timer measures the number of times per second that the light beam is interrupted. Use only one photogate attached to input "A". In frequency mode the "A" button controls the measurement much the same way as in stopwatch mode. Use the "A" button to toggle the "A" light on and off.

- When the A light is on the Timer measures frequency and updates the display every two seconds
- When the A light is off the Timer displays the last frequency measurement and freezes the value.

The Timer II measures frequency in Hertz (Hz) or cycles/second

A frequency of 25 Hertz means that the light beam is being broken 25 times per second. How does the frequency of breaking the light beam tell us the speed of the motor?

The answer depends on the switch plate being used. For the four-pole switch plate the light beam is broken 2 times for each turn of the rotor.

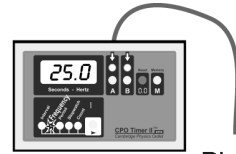

Measurement is 25.0 Hz  
or 25.0 cycles/sec

Photogate

**The rotation speed of the rotor is the frequency divided by the number of black segments on the switch plate.**

Most electric motors are specified in terms of **RPM**, or **revolutions per minute**. To be a good comparison we need to convert our speed measurements (in rotations per second) to rpm. For example, if the motor turns 20 times per second, and there are 60 seconds in a minute, then the speed of the motor is  $20 \times 60 = 1,200$  rpm.

$$RPM = \frac{\text{rev}}{\text{sec}} \times \frac{60\text{sec}}{\text{min}}$$

### The 6 Pole Switch Plate Example Calculation



The 6-pole switch plate has 3 black segments around the rim and therefore breaks the light beam 3 times per revolution. The rotation frequency for this plate would be the frequency measured by the Timer divided by three.

**Timer measurement: 33 Hz**

Rotor frequency =  $33 \div 3 = 11$  rev/sec.

Rotor speed =  $11 \times 60 = 660$  rpm

## Adjusting the Timing of the Motor

The motor will work best when the electromagnet switches in the right place relative to the magnets in the rotor. Notice that there is a degree scale printed on the switch plate with a circular window so you can see the magnets in the rotor. This scale allows you to tune the motor for maximum speed by adjusting the position of the switch plate.

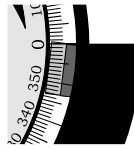

This magnet has its edge at 0 degrees

## Measuring Current and Voltage: Series and Parallel Circuits

A very important characteristic of a motor is how efficiently it uses electricity. How much electricity is needed to get better performance? It might not be worth doubling the speed of the motor if it were to take ten times as much electricity to achieve that speed. The CPO Electric Motor and Digital Meter combined allow a quantitative exploration of the compromise between power usage and performance.

There are three units that are necessary to understand. Amperes (or amps) measure the flow of electric current. Volts measure the potential that causes the current to flow. Watts measure the total electric power. For the DC motor, the power is given by the product of the voltage and the current measurements.

- Amps are a measure of electric current
- Volts are a measure of electric potential
- Watts are a measure of power.

An **electric circuit** is a path that electric current can flow around. The diagram on the following page shows the simple electric circuit that is used in the Electric Motor. The battery provides the voltage that pushes the current through the electromagnet. In the Electric Motor experiment parts of the circuit are wires, you can see them on the bottom of the Motor. Other parts of the circuit are on the circuit boards, in the silver screws and in the coil itself. The circuit diagram for the motor is printed on the wood body.

Electric current flows around the circuit from high voltage (1.5V) to low voltage (0V).

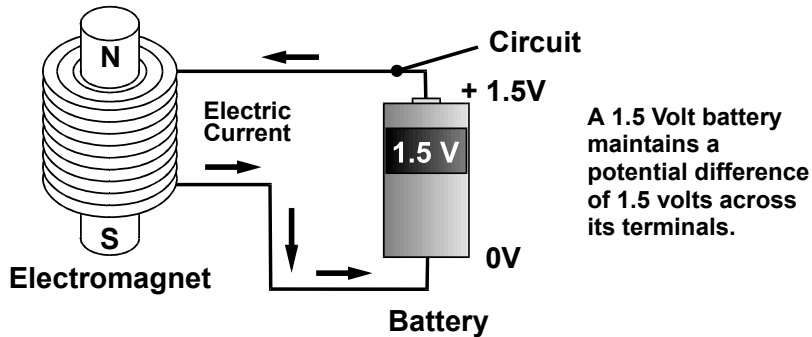

There is more than one way to connect two or more electromagnets. These two most common ways are called series circuits and parallel circuits. The diagram that follows shows how the two circuits look in diagram form. It is usually good to remind students that the solid lines that are so neat in the diagram represent wires that might be all twisty and curved in real life. Electric current does not need to flow in straight lines so bending the wires does not change the circuit. The Electric Motor is wired with all the Electromagnets in parallel. This can be shown experimentally by noting that the current drawn by the motor increases when another magnet is added.

### A parallel circuit with two electromagnets

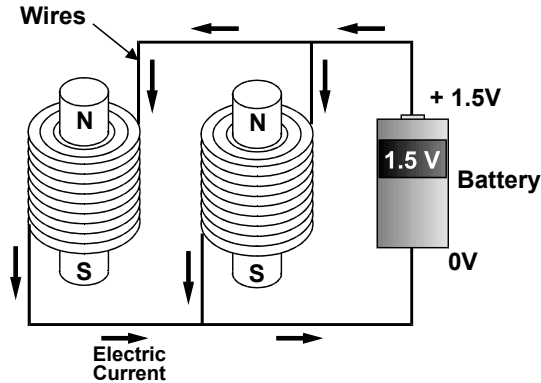

### A series circuit with two electromagnets

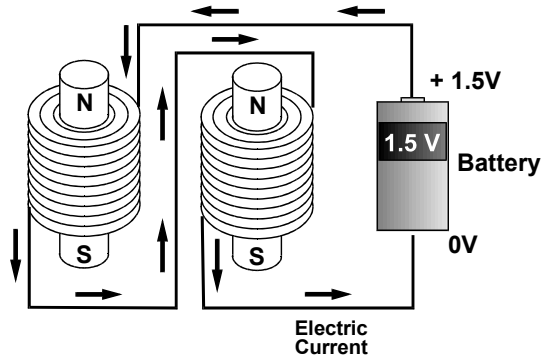

## Measuring Voltage

Voltage is always measured from one place on a circuit to another. You can think of measuring voltage as hooking your meter up in parallel with the points on the circuit you are measuring the voltage between.

For example, the Digital Meter can be (and should be) used to measure the voltage (potential) of the battery pack. A fully charged battery pack should give a voltage of more than 5.5 volts DC. If the battery pack becomes weak successive motor experiments will not produce consistent results. The diagram that follows shows the digital meter connected to the battery pack.

### Connecting the Digital Meter to measure the battery pack voltage

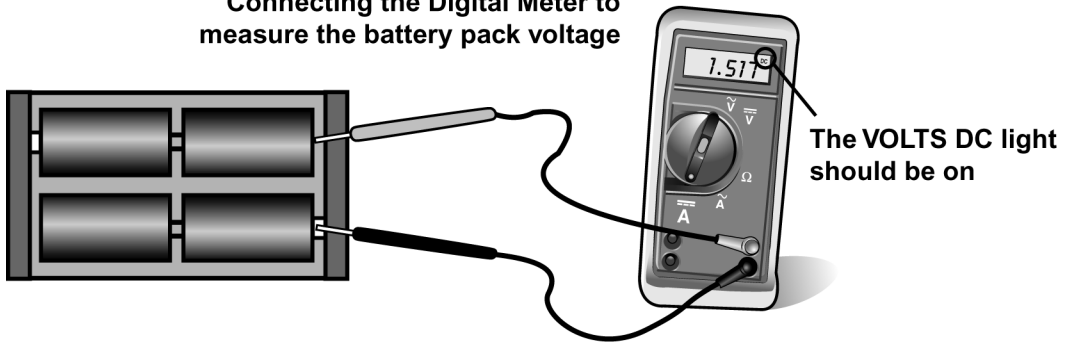

### Measuring Current

Voltage is what makes current flow. Current flows from high voltage to low voltage. To measure voltage it was necessary to connect the meter at two different places in the circuit to see which was higher. To measure current, the meter must be connected so that the current flows *through* the meter. Current measurements are made with the meter in series with the circuit.

### Measuring the current flowing in the Electric Motor

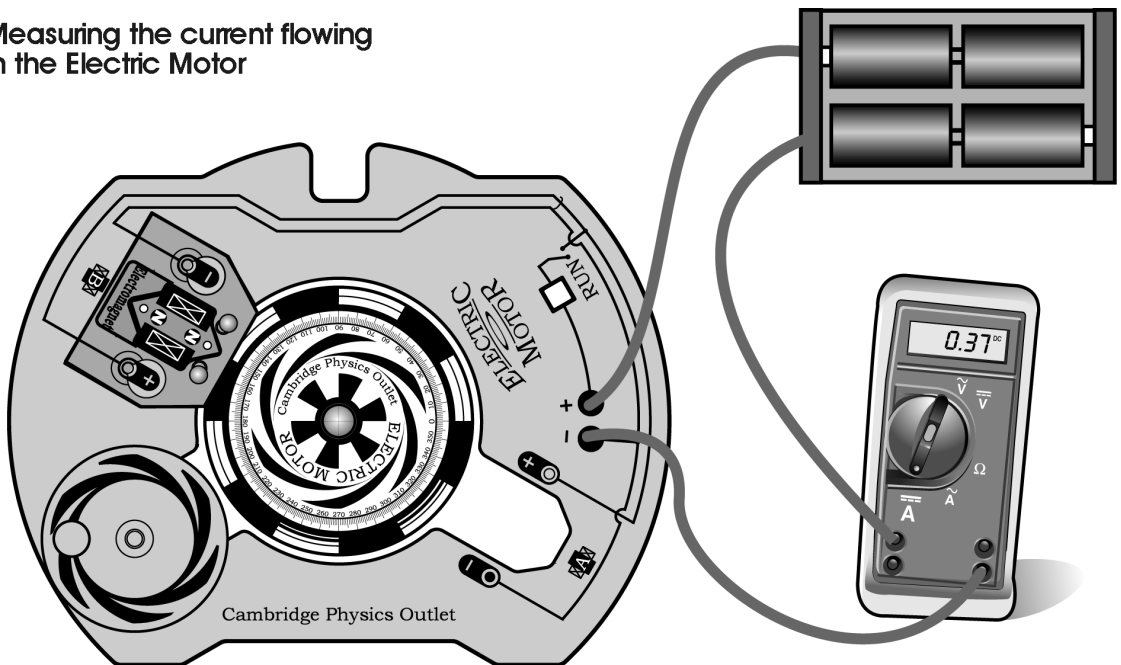

Notice that the current drawn by the motor varies between one amp and several amps depending on how many magnets are attached. The current used by the motor is different when the rotor is stopped and when it is spinning. All electric motors draw higher current when they are stopped or heavily loaded

down. The current is reduced in a spinning motor because the moving magnets create an inductive reverse voltage in the coils as they pass by. This reverse voltage is proportional to the speed of the motor.

## Electric Power

The motor uses energy to turn. This energy is drained out of the battery. The length of time that the battery will last depends on how much power the motor uses. If you were paying for the electricity, you would pay for the power you used.

For DC circuits the power is calculated by multiplying amps times volts. We usually use the symbol  $I$  for current and  $V$  for voltage. If we let  $P$  be the power then the equation for electric power is given below.

$$P = VI$$

where:  $P$  is the power in watts  
 $V$  is the voltage in volts  
 $I$  is the current in amps

A digital meter can be connected as shown below to read the voltage.

**Measuring the voltage (to use with the current-flow measurement) to determine the electric power used by the Electric Motor**

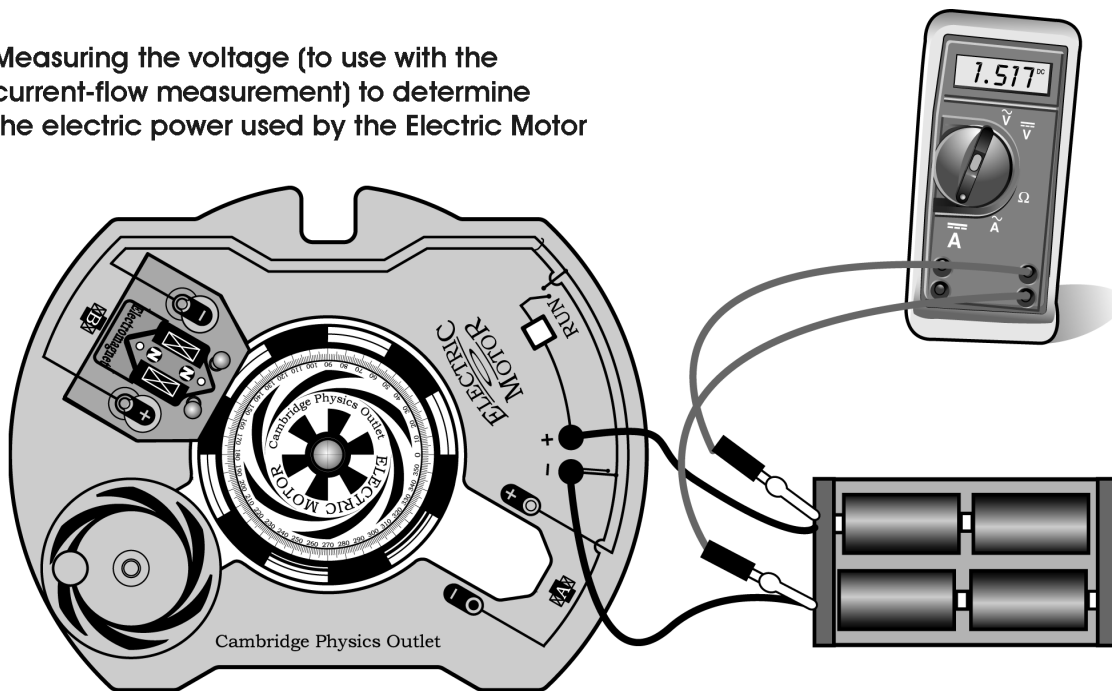

## Using the Generator Module as a Drive Electromagnet

With the two banana-style patch cords, you can attach both the Electromagnet Module and the Generator Module to each other on the Motor and increase the speed of the rotor.

Put the Electromagnet Module in slot A or B and the Generator Module in the opposing slot. Connect the two modules with the patch cords. When the light beam is unbroken, the terminals on the Electromagnet Module have the following polarity: positive on the right and negative on the left (see page 7). The polarity reverses when the beam is broken. Note that all of the current switching must be done by the Electromagnet Module, (as the Generator is passive). This is important when determining how you want to set up your motor for additional speed. Certain switch plate configurations work well, others work poorly.

How does adding the Generator coil as described above affect the efficiency of the motor?